

# GP38 Drop-In Configuration Variables List

This is the list of all CVs used in the GP38 Drop-In. The "Orig Value" column shows the original factory value when new or when the decoder is reset.

CV #	Orig Value	Value Range	Description
CV1	3	0-99	1-99 Primary Address
CV2	9	0-255	Motor Starting Voltage MSV
CV3	2	0-255	Motor Acceleration Rate
CV4	2	0-255	Motor Deceleration Rate
CV5	255	0-255	Maximum Motor Voltage Vmax
CV6	128	0-255	Mid-point Motor Voltage Vmid
CV8	135	135	CVP Manufacturer ID
CV11	0	0-255	Loss of Signal Timer (seconds)
CV17	0	0-255	Loco Address Hi-Byte
CV18	0	0-255	Loco Address Lo Byte
CV29	2	0-255	Decoder configuration
CV35	0	0-99	F1 Function Key Action
CV36	0	0-99	F2 Function Key Action
CV37	9	0-99	F3 Function Key [RCOUPLR]
CV38	15	0-99	F4 Function Key Action [DL On]
CV39	1	0-99	F5 Function Key Action [CRUISE]
CV40	3	0-99	F6 Function Key Action [CAB] [E1]
CV41	0	0-99	F7 Function Key Action
CV42	0	0-99	F8 Function Key Action
CV43	4	0-99	F9 Function Key Action [AUX1] [E2]
CV44	2	0-99	F10 Function Key Action [SMOKE]
CV45	5	0-99	F11 Function Key [AUX2] [E3]
CV46	0	0-99	F12 Function Key Action
CV56	0	0-255	Bump Amount
CV57	0	0 - 127	Bump duration in us
CV59	3	1-15	Headlites Effect Period (x512ms)
CV60	0	0-15	Headlights Mode 0=normal/autorev
CV61	4	0-15	Headlight Front Effect
CV62	4	0-15	Headlight Rear Effect
CV63	0	0-1	Cruise Mode - 0 Norm, 1=Track
CV64	4	1-16	Cruise Track Rate (ms)
CV65	2	1-3	Cruise Track Step Size
CV200	0	0-16	RF Frequency number
CV201	3	1-15	Light Effect Period (x512ms)
CV202	4	0-15	CAB Special Effect [E1]
CV203	4	0-15	AUX1 Special Effect [E2]
CV204	4	0-15	AUX2 Special Effect [E3]
CV205	4	0-15	AUX3 Special Effect [E4]
CV206	0	0-255	AUX3 Auto-off Timer [E4]
CV207	3	0-255	DLites Flash period (x256ms)
CV208	0	0-255	DLites Mode (0=On, 1=Off)
CV209	15	0-255	DLites Flash Timeout (seconds)
CV212	3	0-255	Smoke Timeout (3 minutes)
CV213	8	0-99	Function Key 13 [FCOUPLR]
CV214	6	0-99	Function Key 14 Action [E4]
CV215	99	0-99	Function Key 15 [Cruise Off]

CV Value	Function Key Action
0	No Function
1	Activate Cruise Control
2	Smoke Enable
3	Toggle CAB Lite [E1] on/off
4	Toggle AUX1 Lite [E2] on/off
5	Toggle AUX2 Lite [E3] on/off
6	Toggle AUX3 Lite [E4] on/off
7	Dim Headlights on/off [Rule 17]
8	Activate Front Coupler
9	Activate Rear Coupler
10-14	reserved
15	Activate Ditch Lights
99	Deactivate Cruise Control

CV Value	Special Lighting Effects
0	Off 0%
1	Dim 6%
2	Dim 25%
3	Dim 50%
4	On 100%
5	Strato Light
6	Oscillating Light
7	FRED
8	Rotary Dome light 1
9	Gyra Light
10	Mars Light
11	Rotary Dome Light 2
12	Strobe Single Pulse
13	Strobe Double Pulse
14	Reserved
15	Random flicker

CV Value	Cruise Control Mode
0	Normal (cruise off w/speed change)
1	Tracking mode (Cruise stays on)

CV Value	Head/Rear Lites Action
0	Normal, autoreverse
1	Normal with rule17
2	Front headlite on always
3	Front headlite on always w/ rule 17
4	Rear headlite on always
5	Rear headlite on always w/ rule 17
6	Front & Rear both on
7	Front & Rear both on w/ rule 17
8	Swap F to R Auto Reverse
9	Swap F to R Auto Reverse w/ rule 17
10-15	reserved

© 2019 By CVP Products – All Rights Reserved

P.O. Box 835772 Richardson, TX 75083-577 www.cvpusa.com

Fl March 2019

AirWire900®

# NEW GP38 Drop-In™ Decoder

## Installation Guide

For All Versions of USA-Trains GP38-2

Smart Charger Preparation

GP38 Drop-In™ Decoder Installation

Quick Start Guide

How To Use This Manual .....	2
GP38 Drop-In Decoder Familiarization .....	3
Battery Pack and Battery Charger Preparation .....	4
USA-Trains GP38-2 Disassembly Instructions .....	6
First Generation USA-Trains GP38 Lighting Hookup .....	11
Installing the Optional Phoenix P8 Speaker and Interface Jack .....	13
Mounting the P8 Module .....	14
Mounting the GP38 Drop-In Decoder .....	15
Initial Operation Check Before Reassembly .....	16
Quick Start: Loco Address Set, Loco Frequency Set .....	17
Assigning GP38 Actions to Throttle Function Keys .....	19
Quick Start: Motion, Lights, Smoke, Sound Effects .....	20
Detailed P8 Hookup Diagram and Operating Notes .....	22
Resetting Decoder To Original Settings .....	23
ALT Lighting Socket Pinout .....	23
Phoenix Coupler Sockets .....	23
Listing of CVs for the GP38 Drop-In Decoder .....	Back

**AIRWIRE**®  
**900**

**Drop-In Contents**  
GP38 New Style Decoder  
Charger Pigtail  
New Gp38 Installation Manual  
New Drop-In User Manual

Drop-In, AirWire, AirWire900, AirWire name and logo are registered trademarks of CVP Products © 2019

## How To Use This Booklet

**Locomotive Disassembly and AirWire Drop-in Decoder Installation.** This section starts with the simple task of attaching the appropriate sockets and plugs to the battery and the battery charger. Step-by-step instructions then show how to disassemble the USA-Trains GP38 diesel locomotive. Once the locomotive is opened up, you need to identify the type of lamp wiring is in your locomotive, current or older first gen wiring. Then, the installation of the Phoenix P8 sound module is described followed by the rather simple task of installing the Drop-In decoder. With the installation done, a quick checkout is run and then the locomotive is reassembled.

### Quick Start Instructions

This short section describes how to control the features of the GP38 locomotive using the AirWire throttle. In this section you will find the “cheat sheet” listing the throttle function key assignments for both the locomotive and P8 sound effects.

Some useful items related to changing the Drop-In decoder address and how to reset the Drop-In decoder to its original factory settings finish out the installation manual.

### See The Drop-In Users Guide For Applications Tips

Since this manual is used during installation only, and it is specific to the USA-Trains GP38-2 locomotive, there is a separate Drop-In Users Guide. This guide will have all of the items related to fine tuning and performance optimization, useful application tips and instructions for using the optional ALT lighting features.

## Recommended Battery And Charger

The CVP BAT2 is a 14.8V, 6800mAh, Lithium-Ion rechargeable battery. It is an ideal battery for the GP38. The matching smart charger insures maximum lifetime for your battery. The Drop-In decoder includes a connector to splice onto the charger. The BAT2 can be ordered from authorized AirWire dealers or direct from CVP Products. The Smart Charger is available only from CVP Products. [www.cvpusa.com](http://www.cvpusa.com)

Battery 14.8V, 6800mAh	BAT2
Smart Charger	CHARGER1

## Phoenix P8 Sound Module & Accessories

The Drop-In Decoder is designed to work with the Phoenix P8 sound module. In addition to the sound module, you need a speaker, a P8 Drop-In harness and the Phoenix P8 programming jack. If your installation will not have sound, then you may ignore all steps related to the installation of the P8 sound module. Order these items directly from Phoenix or one of their authorized dealers.

[www.phoenixsound.com](http://www.phoenixsound.com)

Speaker SP-2.5SQ:	824-660
P8 Drop-In Harness	6002-08 [All Drop-Ins]
P8 Programming Jack	6000-55 [All Drop-Ins]

## First Gen Headlight Wiring Connector Is Built-In

Older GP38 locomotives use a different lighting hookup for the front, rear and marker lamps. This new GP38 Drop-In already includes the appropriate matching connector for first generation locomotives. Preparing the locomotive lighting wires and attaching a connector is described on page 11. No extra connectors are required.

## Reset GP38 Drop-In Decoder To Original Factory Settings

This reset procedure applies only to the AirWire Drop-In decoder. It does not affect the attached P8 sound module in any way. When this CV is used, all of your changes to the decoder are erased and the original factory settings are restored. You can do this at any time.

### Step-by-Step Key Sequence Using The T5000 Throttle

Follow these steps to reset your AirWire Decoder to its original factory settings. Remember that any Drop-In decoder on the frequency (even if on a different address) will also be reset. Turn off all other nearby decoders to avoid this problem. Turn on the decoder to be programmed.

- Turn on the T5000 by pushing MENU. Make sure it is set to the same frequency as the decoder.
- Push MENU twice and then push 4 to select Service Programming.
- Enter the CV number by pushing, one at a time, the following keys: \*, 8, \*, and then ENT.
- Enter the value by pushing, one at a time, the following keys: #, 1, 3, 5, #, and then ENT
- Listen for the decoder to beep or chirp signifying the command has been sent.
- Push ESC to exit programming mode.

At this time, the decoder has been reset to factory defaults. It will be on address 3 and frequency 0. Set your throttle to address 3 and frequency 0 to verify reset of the decoder.

**There is no change to the P8 sound module address** with the Drop-In reset command. The P8 will stay on its previously set loco address. To re-sync the Drop-In and the P8, just program the desired loco address with both the Drop-In and P8 power switches set to on.

## ALT Lighting Socket Optional Cable and Pinouts

The GP38 Drop-In decoder has 5 extra light drivers available at the small white socket labeled ALT. If you want to use these extra lighting outputs, you will need to purchase the matching cable and plug to fit the socket. Order part number ALT-6. The plug comes with 24 inches of color coded wire. Much more detail about using the extra light drivers is in the Drop-In User Guide.

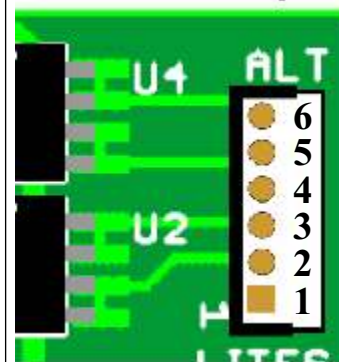

ALT-6 Cable and Plug

Pin	Output	Activate
6	AUX4	F14
5	AUX3	F11
4	AUX2	F9
3	DLR	F4
2	DLL	F4
1	Battery +	na

## Phoenix Front/Rear Coupler Sockets

The GP38 Drop-In decoder includes drivers for two Phoenix solenoid couplers. No extra decoder board is needed. Install the Phoenix coupler on the loco, and insert the coupler's plug into the appropriate socket. The sockets are inside the yellow circle.

The FCP socket is for the front mounted coupler and the RCP socket is for the rear.

The original factory settings are throttle key 3 (F3) for the rear coupler and throttle keys \*, 3 (F13) for the front coupler. You can change the settings if desired.

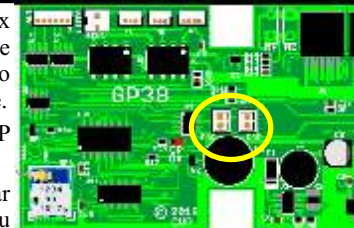

## Phoenix P8 Hookup Diagram



This is the Phoenix P8 hookup diagram. The wires are somewhat stiff and fragile. Don't subject them to a lot of unnecessary flexing.

If not using a P8 speaker, cut off the connector on the two brown speaker wires and solder the wires directly to the speaker.

The sockets are polarized and can only be completely inserted when oriented correctly.

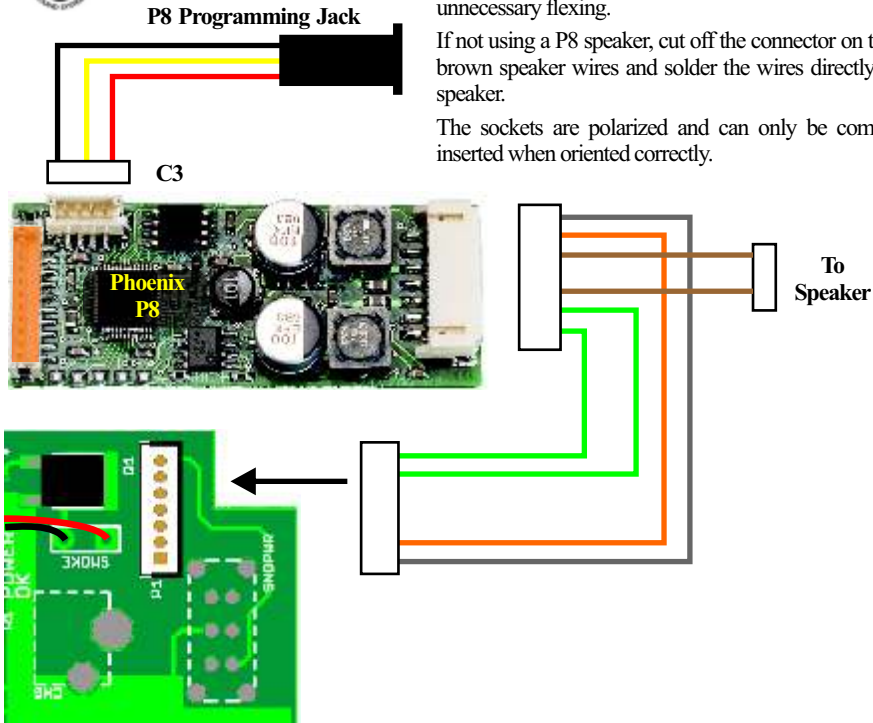

The Drop-In decoder has a dedicated power switch for the P8. The P8 power switch is independent of the Drop-In decoder power switch. When turned on, the P8 is connected directly to the battery. The P8 can be powered while the Drop-In decoder is not.

Don't forget this fact when you turn the sound volume down low or off. Even if off, the P8 draws power from the battery and it will not automatically turn off.

Always use the power switch to shut off the P8.

### P8 Address Setup - Done At The Same Time As the GP38 Address Setup

The Phoenix P8 socket provides DCC commands to the attached Phoenix P8. Be sure to power up both the P8 and the Drop-In decoder when setting the locomotive address. If the Drop-In and the P8 are on different addresses, the motion commands and sound effects will not be properly sync'd. If you discover the P8 is no longer responding to throttle commands but the motion is OK, just reprogram the locomotive address with both motion and sound power switches on.

### Phoenix P8 Sound Decoder Setup - See The Drop-In Decoder Users Guide

The P8 is a versatile sound decoder with many options and selections. However, there are selections that must be made to achieve the best results with the AirWire Drop-In decoder.

Detailed P8 setup instructions are contained in the Drop-In Decoder Users Guide. Also, be sure and see the P8 manual and read the help screens that are part of the Phoenix programming software.

## GP38 Drop-In Decoder Familiarization

Wire lengths are not shown actual size. The wires are long enough to reach all of the required connections



Bottom view of board showing charger jack and power switches

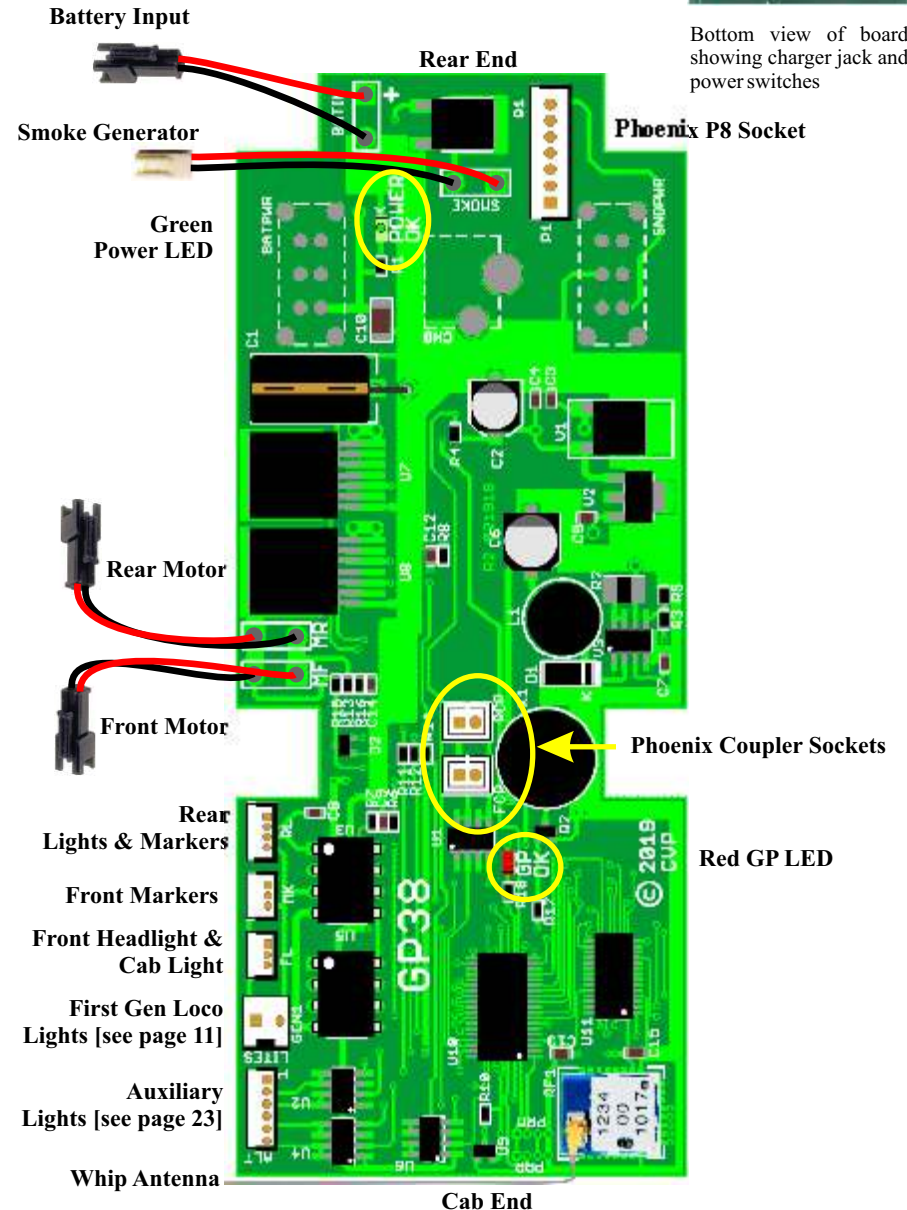

Bend the whip antenna so it is vertical to the board for best reception. It is OK to rotate the gold antenna jack.

## Verify Battery Pack Connector Polarity

### Proper Battery Polarity Is Mandatory

Incorrect polarity will damage the decoder. This is not covered by the decoder warranty. For the Lithium battery, the plus wire is red. The black wire is minus. For the battery plug, the plus wire is also red and the minus wire is black.

### Locate The Drop-In Battery Input Socket

The motor connector and the battery connectors look the same. Be careful. **DO NOT** accidentally plug the battery into the motor connector. This will damage the Drop-In board.

### Check The Battery Pack For Proper Polarization

The CVP BATT2 battery pack has a mating plug that is properly polarized for the Drop-In battery input socket. The drawing shows the red and black wire orientation for both the plug and the socket.

### Visually Confirm Wire Color And Polarization

Orient the battery plug and the Drop-In battery socket as if they were to be inserted. Confirm the wire colors and connector orientation match the picture to the right. Notice that the socket release lever is pointing away from you.

### BATT2 Battery Plug

Black Negative Minus  
Red Positive Plus, +



Locking Tab Faces Away

Lock Release Lever Faces Away



Red Positive Plus, +  
**Drop-In Battery Input Socket**

CVP'S BATT2 Battery Pack



*If you are using a different battery, you must properly identify the PLUS wire. If you get the polarity wrong, you will damage the Drop-In decoder and the warranty does not cover this. If you are not sure, seek help - don't guess.*

## Battery Safety

### Charging Precautions

- Use only a battery charger designed for 14.8V Lithium-Ion packs.
- Li-ion battery packs must be charged correctly and with the correct charger.
- Improper charging will shorten the pack's lifetime.
- Improper charging may cause overheating, fire or explosion.
- We strongly suggest the use of the matching CVP Smart Charger.
- Never use a conventional DC adapter to charge the battery module.

### Battery Protection

- Never drill, puncture or open a lithium battery pack.
- Never cut both battery wires at the same time!

### Off-Season Battery Storage (3 months or more)

- Store in a cool, dry and well-ventilated area. Best temperature range is between 32F and 80F.
- Keep away from the fire and sources of high temperatures.
- Avoid storing a fully discharged or a fully charged battery. If the battery is about 40% to 70% of full charge, it is OK to store it in that condition for about 3 to 4 months.

## Quick-Start Instructions - *Continued*

**Coupler clang** is triggered by F3. Trigger means the sound effect is transitory and sounds each time the key is pressed. This will also open the optional Phoenix rear coupler (if installed.)

**Grade crossing horn** is triggered by F4. This is a 15 second recording of a complete grade crossing horn sequence.

**"All Aboard" station announcement** is triggered by F5.

**Compressor start up** triggered by F6. The sound effects runs for a few seconds and then shuts off.

**Volume Up** is triggered with F7. To use this feature, push F7 to begin increasing the overall Phonenix sound volume. When the volume reaches the desired level, push F7 to stop and hold the volume setting.

**Volume Down** is triggered with F8. This works the same as F7 except the volume will begin to decrease when F8 is pushed. Push F8 again to stop and hold the volume setting.

**Caution: if the volume is allowed to decrease to 0 or off, the volume will remain at 0 when the power is turned off. When turned back on, you may think there is a problem with the sound when in fact you simply have to push F7 to raise the volume.**

**Dynamic Brake** is toggled with F9.

**Brake release** sound is triggered with F10.

**Air Pop Valve** sound effect is triggered with F11.

**Diesel Engine Shutdown** is triggered with F12. This will initiate the shut down sequence for the diesel engine. You can manually restart the engine by simply pushing F12 again. Note that if the throttle speed setting is not idle, the diesel automatically restart. This applies when the locomotive is standing still too. Any change of the speed control will automatically restart the diesel engine.

**Front Coupler activation is done with F13.**

This table shows the combined list of the original factory settings for the GP38 Drop-In along with the recommended function key assignments for Phoenix P8 sound module. Black is the effect for the Drop-In decoder and red is the effect for the P8.

Throttle Key	Locomotive Effect (black) and/or - P8 Sound Effect (red)
0	Toggle headlights, number boards, markers
1	Toggle bell
2	Manual horn activation
3	Trigger coupler clang sound
	Activate Rear Coupler
4	Trigger grade crossing horn sequence
5	Enable cruise control - change speed or direction to cancel
	Trigger station or hotbox announcement
6	Trigger compressor sound effect
	Turn on cab interior lamp
7	Volume up - push to ramp up, push to stop
8	Volume down - push to ramp down, push to stop
9	Toggle dynamic brake sound effect
*0	Toggle smoke generator [two minute timeout]
	Trigger brake release sound
*1	Trigger air pop valve
*2	Toggle engine shutdown or startup sound sequence
*3	Activate Front Coupler

## Quick-Start Guide

### Locomotive Motion Control

Now that the locomotive is reassembled, its time to begin exploring some of its new features and capabilities. These two pages show all of the features using the original factory settings.

As you become familiar with your locomotive performance, you will undoubtedly want to make changes as well as fine tune its operation. Detailed instructions for fine tuning are contained in the accompanying Drop-In User Guide. For now, lets concentrate on basic operation.

**Speed and direction** are controlled from the throttle. Use the throttle's knob to change speed. To change direction, push the direction key. "Forward" direction is defined as if you were sitting in the locomotive cab.

**Cruise control** activation is easy. Once the locomotive is running at the desired speed, push F5 to activate cruise control. A beep will be heard when cruise control is activated. To deactivate cruise control simply change the speed or direction. A beep will be heard when cruise control is deactivated. At very slow speeds, you may hear a double beep. This means that the locomotive is going too slow for reliable cruise control so you need to increase the speed slightly and push F5 again.

### Locomotive Lighting and Smoke Generator Control

**Headlights, number boards and marker lights** are toggled on and off with the throttle's 0 key. This is function 0 which we shorten to F0 The headlights automatically switch between front and rear when direction key is pushed.

**The Cab interior light** is toggled on and off with F6.

**Smoke generator** is toggled on and off with F10. Once turned on, the smoke generator has an automatic 3 minute timeout. The timeout period can be changed and is discussed in the Drop-In User Manual. Note, if the smoke fluid has run out, the locomotive's own smoke generator controller will turn off even if the 2 minute timer has not run out. But the circuit is unreliable so don't depend on it.

### Phoenix P8 Sound Effects Control

The table on the next page assumes you have used the recommended configuration file or have set up the P8 to match our recommended settings (see page 21). If you have not yet configured the P8, the sound effects and throttle activation keys will not match and the sound may shut off after only a few minutes of operation. This is normal if the configuration has not been changed - it is not a Drop-In or sound module problem.

**Bell** is toggled on and off by F1. Toggle means push and release the F1 key to turn on the bell. To turn off the bell, push F1 again.

**Horn** is activated by F2. This is a momentary activation which means push to turn on and release to turn off. There is an automatic timer tied to the horn activation. Sometimes, when the horn is activated, it does not receive the turn off command. This can be caused by motor noise, distance from the throttle or momentary jamming. To prevent the horn from being stuck on, the Drop-In decoder will automatically shut off the horn.

*continued on the next page*

**Don't forget to reattach the exterior details such as the horn assembly.**

## Attaching Charger Plug Pigtail To Charger

First, open up the charger box. Inside will be the charger with alligator clips and the AC power cord.



Locate the charger pigtail that came with your AirWire Drop-In decoder. The 2-conductor pigtail comes with stripped wires on one end and a right angle plug on the other.

The pigtail needs to be permanently attached to the charger output wires. This is not difficult and no special tools are needed.

**Wire polarity is very important** and reversing the polarity could damage the charger or the battery or both. On the pigtail, the plus wire is the wire with the white stripe. The minus wire is the solid black wire. The charger uses the conventional red wire for plus and black for the minus wire.

**Take the pigtail** and separate the 2 wires for about 2 inches. Cut the plus wire so it is 1 inch shorter than the minus wire. Remove about 1/2 inch of insulation from the plus wire. Twist and apply solder to the twist end of the plus wire. This is called tinning and keeps the twisted wires from unraveling. Next, remove about 1/2 inch of the insulation from the minus wire. Twist the strands together and touch a tiny bit of solder to the twisted wire.

**Take the charger** wires and split the red and black wires apart for about 3 inches. Cut off the alligator clips and cut the minus (black) wire so it is shorter than the plus (red) wire. Remove about 1/2 inch of the insulation from both the black and red ends of the wires. Twist and tin the wires.

If you are using heatshrink tubing to insulate the solder joints, now is the time to slide a piece over the minus wire. Otherwise, use electrical tape to insulate each connection. Overlap or twist together the two minus wires and solder them together. Once the solder joint has cooled, slide the heatshrink over the connection and heat it up to shrink the tubing around the connection. Make sure no wire is visible.

Slide a piece of heatshrink over the plus wire. Overlap or twist together the two plus wires and solder them together. Once the solder joint has cooled, slide the heatshrink over the connection and heat it up to shrink the tubing around the connection. Make sure no wire is visible.

Inspect for proper polarity matching and that no bare wire is visible outside the heatshrink tubing. This completes the wiring.

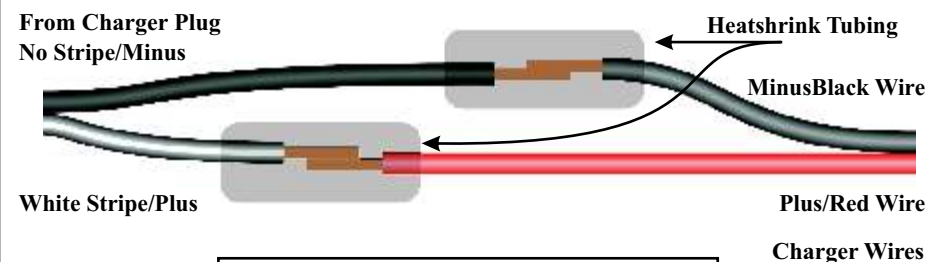

Heatshrink tubing may be ordered from Mouser Electronics. Use 0.25 inch diameter tubing with part number 5174-1141. It sells for about \$2 and comes in a 4 foot length. [www.mouser.com](http://www.mouser.com)

## USA-Trains GP38-2 Disassembly

**Warning:** Many parts of the shell and chassis are fragile and easily break. Especially vulnerable are the steps, doors, side-frame assemblies, and cab awnings. Gently pull up and remove the horn assembly if it has been installed. The radio antenna is especially vulnerable so remove it if possible or take care not to break it.



### You Must Have The Proper Screwdriver

You must have a thin-shafted, #1 phillips-head screwdriver that is at least 4 inches long to reach the screws. The thin shaft is necessary to fit between the wheel and side frame. This one is from General and has a 4 inch long, narrow shaft with a #1 Philips tip. It is also magnetized which comes in handy for pulling the screws from deep recesses.



### A Soft Work Surface Pays Big Dividends

Spread a couple layers of thick towels on your work surface to serve as a cushion for the locomotive. The top of the locomotive is uneven and is unstable when upside down. The towel will help prevent damage should it fall over.

### Use a Foam Block To Hold Screws

Take a rectangular sheet of foam and label it B and F to represent the loco's front and back end. As each screw is removed, position it in the foam in about the same location as found on the locomotive.



### Total Mounting Screw Count is 16

When all the screws are removed, there will be a total of 16 screws. When you are done, If your count doesn't match, go back and check to see which ones you missed. The next series of illustrations shows the location of the screws and have been numbered for easy reference.

### Remove Fuel Tank - 2 Screws

The 2 screws are number below and the black circles are where you will find the screws. Remove the 2 screws, lift off the tank and set it aside for now.



## Assigning GP38 Actions To Throttle Function Keys

A function key on the throttle is generic. When pressed, it only sends an activate or deactivate command. For example, pushing the throttle's 5 key sends the command "activate function 5." What the decoder does with the function command is determined by the setup inside the decoder (not the throttle).

You can change what your new GP38 decoder does with any of the received function key commands except function 0. Function 0 is fixed and is set to always turn locomotive headlights on or off.

### Changing Decoder Function Key Actions

Use this step-by-step sequence to setup what the decoder does when it receives a specific function key command. The setup is stored in the decoder's memory. The throttle does not store anything.

The GP38 Drop-In has many memory locations where setups are stored. We use the term CV# where # is a specific memory location. So CV40 means GP38 memory location number 40. The value stored at this location dictates what the decoder does when it receives a throttle's function key command.

Deciding the setup is relatively simple. Start by thinking through what you want your throttle to do to the GP38 decoder. For this example, here's what is wanted:

**"On the throttle, when I press the 6 key I want to turn on the smoke generator."**

Notice the underline of the important items: which throttle function key is to be used, and what the decoder action will be when that key is pushed. For this example, F6 is the throttle's 6 key. Now you are ready to set the GP38 Drop-In so that it turns on the smoke generator when F6 is pressed.

**Step 1:** Find F6 in the Function Key Assignment" table.

*From the table, the GP38 decoder uses CV40 for F6.*

**Step 2:** Find the desired action in the "Function Action" table and note the value. This will be what is stored in CV40.

*For this example, since the smoke generator is to be toggled, which means turned on and off, the CV value of 2 is to be used.*

**Step 3:** Turn on the decoder's power. Set your throttle to the decoder's frequency and locomotive address if it has not yet been set. This is very important since if either the frequency or the locomotive address is wrong, the GP38 will not hear the throttle's OPS PROGRAM command.

**Step 4:** OPS PROGRAM CV40 to a value of 2. The decoder will chirp indicating it heard and accepted the command. Escape out of OPS PROGRAM and verify that the GP38 Drop-In's smoke generator turns on when the throttle's 6 key is pressed.

**This same sequence is used to assign or change what any of the available function keys do.**

Function Key Assignment	CV#	Reset Value	Function Key Action	CV Value
F1 Function Key Action	CV35	0	No Function	0
F2 Function Key Action	CV36	0	Activate Cruise Control	1
F3 Function Key Action	CV37	9	Smoke Enable	2
F4 Function Key Action	CV38	15	Toggle CAB Lite [E1] on/off	3
F5 Function Key Action	CV39	1	Toggle AUX1 Lite [E2] on/off	4
F6 Function Key Action	CV40	3	Toggle AUX2 Lite [E3] on/off	5
F7 Function Key Action	CV41	0	Toggle E4 [not available] on/off	6
F8 Function Key Action	CV42	0	Dim Headlights on/off	7
F9 Function Key Action	CV43	4	Activate Front Coupler	8
F10 Function Key Action	CV44	2	Activate Rear Coupler	9
F11 Function Key Action	CV45	5	reserved	10-14
F12 Function Key Action	CV46	0	Activate Ditch Lights	15
F13 Function Key Action	CV213	8	Deactivate Cruise Control	99
F14 Function Key Action	CV214	0		
F15 Function Key Action	CV215	99		

## GP38 Drop-In Installation

### Common Errors and Fixes

*Green Power LED doesn't turn on:* Make sure the Drop-In decoder power switch is on. The power LED does not turn on even though the sound module is operating OK.

*Red GP LED only has a very slow flash rate:* This is your indication that the throttle has turned itself off, or the throttle frequency doesn't match the locomotive frequency.

Make sure everything checks - you don't want to have to take the locomotive apart more than once.

### Mount the Fuel Tank

Place the fuel tank near its mounting location on the locomotive. Push the programming jack's connector up through the hole in the floor. Plug in both the speaker connector and the programming connector.

Orient the small whip antenna straight up. Keep it away from all wires.

Use tie wraps to keep wiring in place and out of the way of all mounting holes. Neatness really counts and will prevent troubles and broken wires during locomotive reassembly.

The most common problem are broken light wires when screwing down the shell to the chassis.

### Closing Up The Locomotive

This will take a few minutes so don't rush - take your time. Bring the top half down onto the chassis slowly and carefully. Make sure all wires are INSIDE the mounting posts. Don't allow a wire to fall on the outside of the post or you risk pinching it when the top half is mated to the bottom half. Also push the smoke generator wires towards the rear of the locomotive. Keep them away from the antenna. Look on both sides of the locomotive. Make sure you can't see any wires. The antenna is usually the one that escapes.

The top half will seat itself correctly and easily when everything is aligned. It is easy to be off by a small amount which will prevent the two halves from mating. Inspect all around. If resistance is encountered, check for wires that may not be inside the mounting posts. The rear headlight wires are usually the ones that slip outside the mounting posts.

Once the two halves are together, turn the locomotive upside down. Once again check for alignment of the two halves. Install the two chassis screws that are hidden by the fuel tank. To start the screw, first turn it slightly counter-clockwise to get it seated in the threads, then turn it clockwise to tighten. Do not over tighten. Then attach the fuel tank. Finish the reassembly by installing the remaining screws.

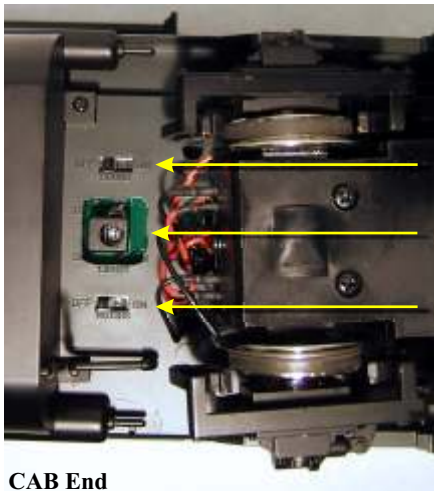

### Power Switches And Charger Jack

*The switch legends embossed in the plastic are backwards for the GP38 Drop-In. The switches are ON when both switches are towards the CAB.*

Phoenix P8 Module Power Switch [shown ON]

Battery Charger Jack

GP38 Drop-In Decoder Power Switch [shown ON]

Slide Switch Actuator  
Towards CAB = ON



Slide Switch Actuator  
Towards Rear = OFF



CAB End

## USA-Trains GP38-2 Disassembly

### Front End Mounting Screws - 8 Screws

There are two types of screws in this area with one set visible and another set buried deep inside hollow tubes. The circled number is the approximate location of each mounting screw.

The black circled screws are visible. The red circled screws are deep inside hollow columns. The 4 inch long screwdriver must be used to get these out.

The front truck is easily rotated to expose the hollow tubes. Take care not to damage the truck wiring. Be careful and do not damage the side frame's delicate detail.

As each screw is removed, place it into the foam block.

If the screw does not come out of the hole, give it several more turns to insure it has released from the upper shell. It will come out when the shell and the chassis are separated. their access holes.

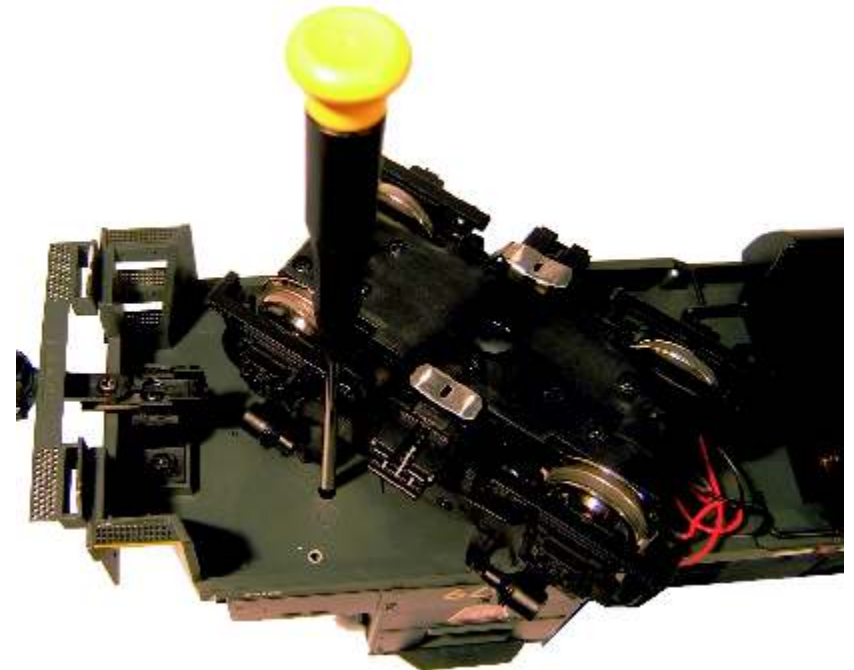
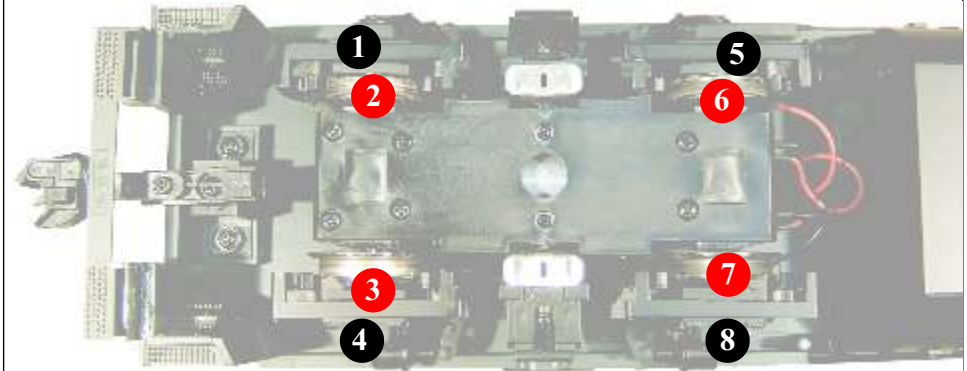

## USA-Trains GP38-2 Disassembly

### Under Fuel Tank Mounting Screws - 4 Screws

With the fuel tank removed, 4 more mounting screw holes are exposed. Use the long shafted driver to remove these screws, #9, #10, #11 and #12.

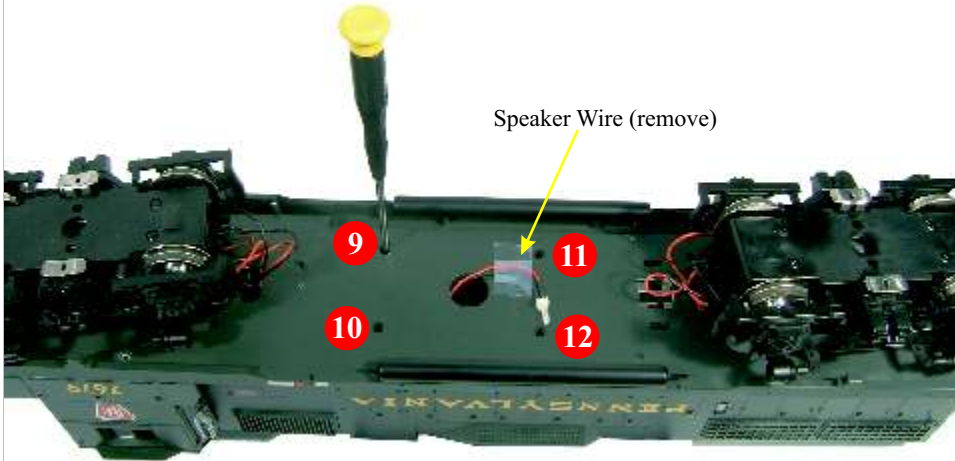

### Rear Mounting Screws - 4 Screws

The last 4 screws are under the rear truck. Unfortunately, two of the screws, #15 and #16 are difficult to reach since the truck obstructs the hole. It is the long shaft screwdriver that does the trick. The last two will be saved for last.

Let's do the easy ones first. Slightly rotate the truck to expose the hole. Remove the two screws, #13 and #14.

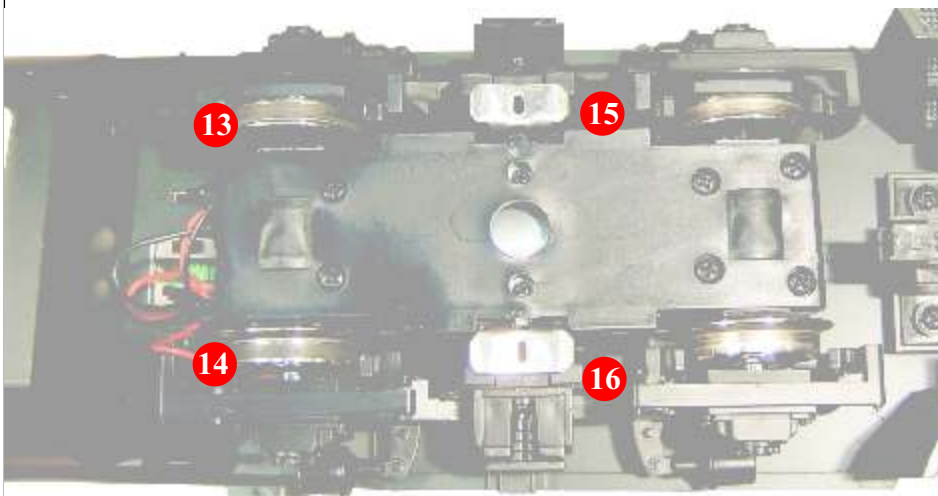

You can remove and discard the track sliders since they are no longer required

## Quick Start - Setting Locomotive Address and Frequency

The "Quick Start" section assumes you have already installed your Drop-In. As delivered from the factory, the Drop-In's frequency is set for 0 and the locomotive address is 3. It is also assumed that the shell has not been reattached to the chassis allowing you to see the Drop-In's LED indicators.

### Step 1: Turn Power on to the Drop-In and Turn on Throttle

- The Drop-In's power green LED will glow brightly indicating power is connected.
- If you have not done so, set the throttle to frequency 0. Assuming your Drop-In still has the factory default address setting, also set the throttle's locomotive address to 3.
- When the throttle is turned on to the proper frequency, the red GP LED will be on. If the red LED is not on, then your throttle is not on the proper frequency. Do not proceed to step 2 until both red LEDs and both green LEDs are on.

### Step 2: Set the Drop-In Decoder's Address

- On the throttle, select SERVICE PROGRAM mode. Just press the green menu key twice and then push the number 4.
- Now push 1 and push ENT which selects CV1 for changing the decoder address.
- Key in the decoder address numbers that you want to use. The address must be unique. The loco's cab number is always a good idea. Once you have entered the numbers, push ENT. [Address 0 is not allowed].

### Step 3: Set the Throttle To The New Address And Verify That The Loco Runs

### Step 4: Changing The Drop-In's Frequency

- Select SERVICE PROGRAM mode on the throttle.
- Enter 200 followed by ENT. CV200 is where the desired frequency (from 0 to 16) is stored in the Drop-In decoder.
- Enter the desired frequency number and push ENT. Your Drop-In is now on the new frequency. Verify the red GP LED is on when you set the throttle to the new frequency.
- Push ESC to cancel SERVICE PROGRAM mode.

### Step 5: Set the Throttle To The New Frequency And Verify That The Loco Runs

## Quick-Start - Resetting The Drop-In Frequency

There may come a time when your locomotive no longer responds to what you believe is the correct frequency, or you can not remember the correct frequency. Here's how to reset the frequency

**Step 1** Turn off all AirWire throttles. This is very important since it is the of the absence of a throttle signal, plus a decoder power-cycle (turning the decoder's power off and then back) that allows the decoder to temporarily jump to frequency 0 where you can set a new frequency.

**Step 2** Turn off the Drop-In decoder if it was powered on.

**Step 3** Turn on the Drop-In decoder and wait at least one minute. Do not turn on any throttles during this time. At the end of one minute, the Drop-In beeps 5 times and temporarily sets itself to frequency zero. This is only temporary.

**Step 4** Turn on your throttle, and set the throttle for frequency 0. You will notice the Drop-In's red GP LED is on. The locomotive address does not matter when using SERVICE PROGRAM mode.

**Step 5** - Push the green MENU key twice and select 4 for SVC PROGRAM.

**Step 6.** Enter 200 followed by ENT for CV200 which is used set the decoder's frequency. Enter a valid frequency number from 0 to 16 followed by ENT. Be sure and make a note of the new frequency. When done, power-cycle the decoder to accept the new frequency. The frequency is stored even without battery power forever or until you change it.



## GP38 Drop-In Installation

### Tidy Up The Wiring

Keep the wires away from the antenna which is the almost clear piece of wire attached to the little radio module. Orient the antenna vertically. Some parts of the P8 become hot when operating so don't let the wires lie on top of the P8.

### Temporarily Plug In Speaker

Before checking the installation, plug the speaker connector into the P8. Don't bother with the programming jack connector at this time, just the speaker.

The next set of steps will check the installation and verify correct operation. A throttle will be required for the next set of steps.

The battery is assumed to be charged.

### Preliminary Checkout

As delivered from the factory, the Drop-In decoder is set to locomotive address 3 and for frequency 0. A factory fresh P8 sound module is also on locomotive address 3. Check that your throttle is set to loco number 3 and frequency 0. However, if you have previously programmed the Drop-In and P8, then set the throttle to the appropriate frequency and loco number.

1. Turn on the throttle and set it for address 3. Also set the throttle to frequency 0. See your throttle manual for how to do this.

2. Turn on both power switches on the drop-in. The ON position is with the slide switch actuators towards the cab. The Drop-In's green LEDs will be on indicating battery power is present.

3. You will hear the Phoenix P8 module turn on (if installed). Don't be alarmed if the sound turns off in a minute or so - that is normal and can be changed. Changing this feature will be discussed later.

4. Locate the green LED on your GP38 Drop-In decoder. It is labeled POWER OK. It will be glowing bright green when the battery is connected and the power switch is turned on.

5. Locate the red LED on your GP38 Drop-In decoder. It is labeled GP OK. When the red LED is on, it indicates it is receiving the throttle.

4. Set the throttle for forward and slowly turn up the speed until the motor start to move. Verify that both motors turn in the same direction and that the loco moves forward. If the loco goes reverse instead, then the two motor connectors are reversed.

5. Turn on the locomotive headlight by pushing the 0 key on the throttle. If the throttle is set for FORWARD, the front headlight will be on. Change directions and confirm the rear headlight turns on. Push 0 to turn off the headlights. *If your unit is using the 1st generation light wiring, you can only turn the lights on and off. Skip step 6 since you won't have control of the individual lights.*

6. Push the \* key followed by the 1 key. This will turn on the cab interior and the number boards. Push \* and 1 again to turn them off.

7. Push the \* key followed by the 0 key. Listen carefully for the smoke generator's fan. Push \* and 0 again to turn it off. Since there is no fluid in the generator it can only be run for a few seconds.

8. If you have installed the Phoenix sound decoder, push the 2 key and the P8 horn will sound.

This concludes the preliminary checkout.

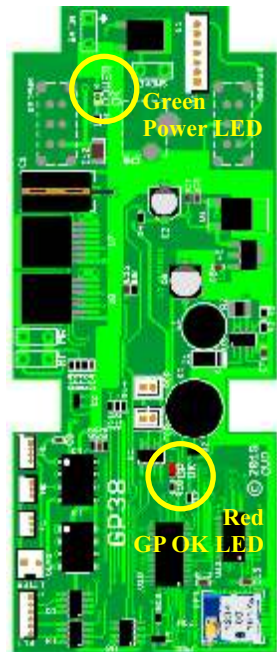
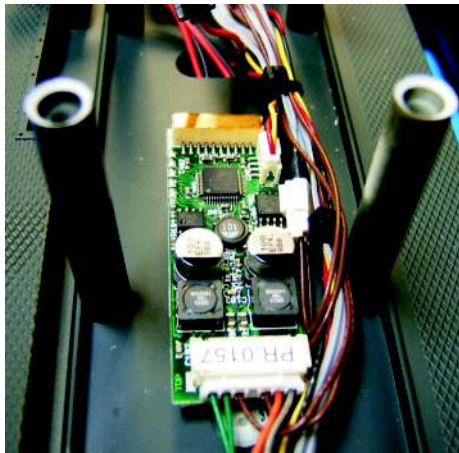

## USA-Trains GP38-2 Disassembly

### Final 2 Mounting Screws

The last two screws are located under the truck and it can not be rotated out of the way. Instead, slide the screwdriver between the side frame and the truck, just behind the wheel.

Let the tool center itself in the screw head and remove the screw. If you are using a magnetized tool, you can try and lift out the screw. However, as you get close to the motor, the motor's magnet may snatch the screw and stick it to the motor. Be sure and retrieve the screw before continuing.

Repeat this for the other screw and you are done.

This concludes the screw removal. The top chassis half is now separated from the bottom chassis half. Count the screws and make sure there are a total of 16.



### Separating the Top and Bottom Chassis Halves

"Gently" is the key word for this task. Starting at the back end, gently lift the top half of the chassis away from the bottom. If you feel any resistance, go back and verify all screws have been removed. The two halves should come apart easily. Place the top half on its side. Be careful of the small wires that join the two halves. The cab window shades are very fragile and easily broken - take care.



### Present Generation Locomotives - Only Unscrew Transistors From Both Weights

There are two transistors, each mounted to a lead weight. Remove the screw and the brass washer from each transistor. These 2 screws and 2 washers are no longer needed and can be discarded.

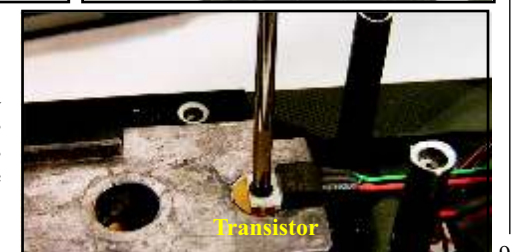

## USA-Trains GP38-2 Disassembly

### Unplug All Connectors From Board

This is relatively easy. Unplug all the connectors from the circuit board. Remove and save the little twist ties. These can be used later to bundle wires.

Present generation locos use miniature 3 and 4 wire sockets. The plug is held tightly by friction. The easiest method to remove these is to grasp the group of wires near the plug. Next put your thumb on the top of the circuit board to prevent flexing. Now pull upwards while gently rocking the plug from side to side. This will release the plug from the socket.



Remove the USA-Trains speaker wires (shown on page 8) that go down through the hole in the floor. The connector and wires are not needed and may be discarded.

See below for what to do about the two smoke generators and their controller boards.

Finally, remove the 3 screws holding the main circuit board and remove it. The board is no longer needed but be sure and save the screws to mount the Drop-In decoder.

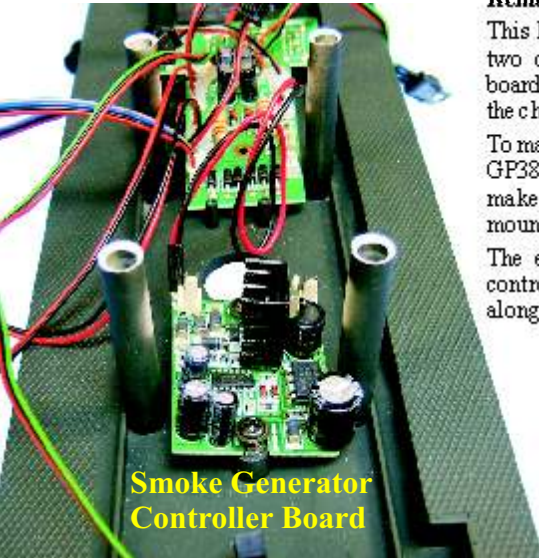

**Smoke Generator Controller Board**

### Remove The Bottom Smoke Generator Board

This locomotive has two smoke generators and two controller circuit boards. One controller board is in the roof and the other is mounted on the chassis floor.

To make room for the sound module, battery and GP38 Drop-In decoder, you have a decision to make: get rid of one controller circuit board or mount the extra board in the shell's roof.

The easiest choice is to simply eliminate the controller board mounted on the chassis floor along with its accompanying smoke generator. That is what's shown in this installation.

Remove the smoke generator board from the chassis floor. The two screws are not needed and may be discarded.

Remove the now disconnected smoke generator from the chassis. Leave in place the 2nd controller board in the roof and its smoke generator. These will be connected to the Drop-In decoder later.

### Removing The Rear Truck

The rear truck and the connecting wires are in the way of the work that needs to be done to enlarge the switch holes. Removal is easy and insures the truck's wires are not damaged.

Remove and discard the two screws holding the weight to the chassis. The remaining screw and washer are what holds the truck to the chassis. Remove the screw to free the truck. Gently push the truck wires through the chassis hole and set the truck aside. Put the screw and washer back into mounting hole on top of the truck bolster so they are not misplaced.



**Truck Bolster Screw and Washer**

**Weight Has Been Removed**

## GP38 Drop-In Installation

*Some photos show the use of our prototype GP38 board. It doesn't have the usual green color and is missing the reference designators. Yours will be the production board with all the usual markings and labels. Physically, the prototype and production boards are identical.*

### Mount The GP38 Drop-In Board

Before mounting the Drop-In decoder, verify that both power switches are off. The actuators will be towards the locomotive's cab when off. Place the decoder onto the mounting posts. Make sure the jack and switches fit through the holes and the board is flush to the mounting posts. Verify that the front motor connector comes out from under the board and is clear of the mounting posts. Use the 3 small screws from the old circuit board to mount the Drop-In board.

### Plug In P8 Connector

The time has come to plug in the various connectors. Start with the white connector from the P8 board. It goes into the matching white socket near the power switches labeled P1. The plug only goes one way so don't force it.



### Plug In Front Motor, Rear Motor and Battery Pack

Plug in the front and rear motor connectors first. Then plug in the battery pack to the BATIN connector located near the P8 socket. Do not accidentally plug the battery into the motor connector.

### Neatness Counts

There will be a wad of wires and connectors near the battery. If you did not remove the pickup wiring, it too will be in this area. Tidy up the area using narrow strips of electrical tape, or plastic tie-wraps. The plastic tie-wraps come from the electrical department of any hardware store and come in many sizes and colors. Our favorite is the lemon-yellow 3 inch tie-wrap because it is easily seen in photos. Form the wires into bundles and use the tie-wrap to hold the bundle together. Make sure the wire bundles fit inside and between the tall mounting posts.



### Shell Lighting Connectors and Smoke Generator

Move the shell near the chassis and orient it so the cab is aligned with the front of the chassis. Plug in the three lamp connectors using the guide below. Slip your finger under the Drop-In board to prevent excess flexing as the connector is inserted. Press the connector firmly into the socket. The smoke generator is connected with the last remaining plug from the Drop-In. The connector is polarized and only fits in one orientation. Make sure it is pushed all the way down onto the pins.

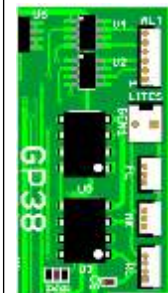

→ Auxiliary Light Outputs

→ First Gen Light Connector (see page 11)

→ Front Headlight & Cab Light

→ Front Markers and # Boards

→ Rear Headlight, Markers & # Boards

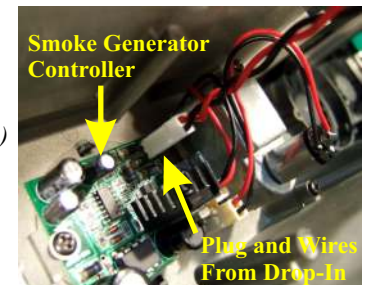

**Smoke Generator Controller**

**Plug and Wires From Drop-In**

## Mounting Phoenix P8 Sound Module

### Remove Four More Unneeded Posts

There are four unneeded mounting posts that need to be cut flush to the floor. The posts interfere with the Drop-In decoder and the sound decoder.

The 4 posts are indicated with the yellow arrows. Use your flush cutters to remove them.

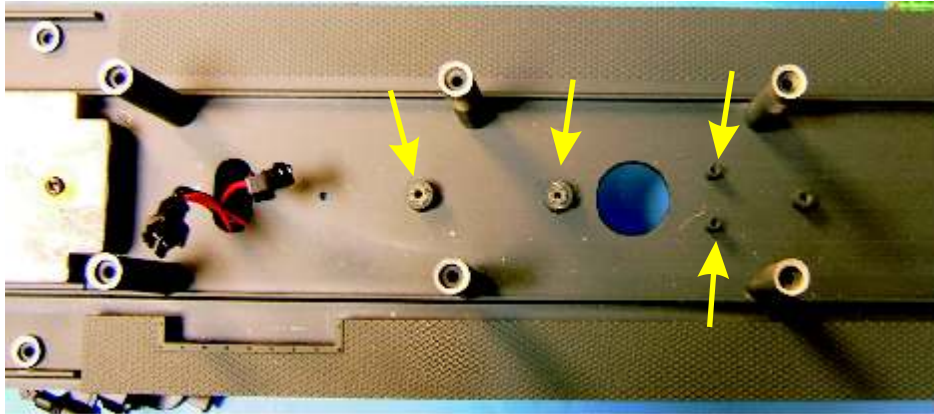

### Mount The P8 Sound Module

The P8 is small and is placed in the free area between the Drop-In and the battery pack. The bottom of the P8 is uneven. Turn over the P8 and place a small piece of double-sided foam tape in the area shown. Then add one more strip across the entire unit. Orient the module as shown below. The white, right angle connector on the end of the P8 needs to face towards the rear of the locomotive.



### Plug in the 6-wire P8 Cable

This Phoenix supplied cable plugs into the right angle connector on the P8 and connects to the speaker and the Drop-In decoder. Push the two brown speaker wires through the hole to get them out of the way. The cable is stiff and will not stay put. Use foam tape to hold the cable to the floor. Place a narrow strip of foam tape between the power switch and the charger jack holes. This insures the wires do not foul the jack or switch hole and are not pinched when the Drop-In is mounted.

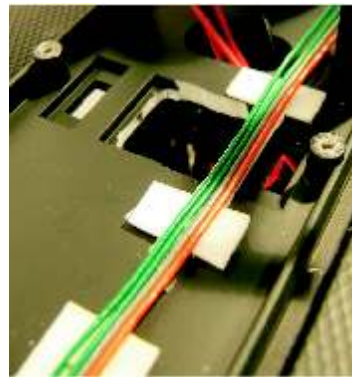
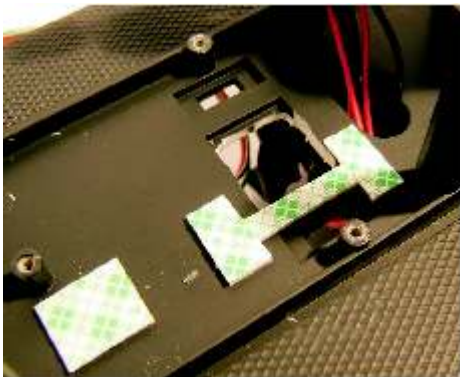

## First Generation G38-2 Main Board And Lighting

### You Must Remove The Original Locomotive Main Board

Similar to the current generation locomotive, the first generation has a circuit board to which the various motor, pickups and lights connect. The early generation also used 18V incandescent bulbs for all lighting except the red/green marker lights.

Disconnect the smoke units, the motors, the track pickups and the 3 lighting connectors from the main circuit board.

Remove the main board after taking out and saving the 3 small screws. These are needed to mount the new Drop-In.

Your new GP38-2 Drop-In has a connector dedicated to the first generation style lighting. But there is only one connector. You will need to splice the locomotive lamp wires together in order to feed all the lights from the single GP38 Drop-In connector.

First, cut off the large white plugs from wires coming from locomotive circuit boards. Make one plug have about 3 inches of wire or more. You can also purchase an optional JST-2 plug from CVP.

Connect the lamp board wires together as shown and connect the plug as shown. Solder all wires. Then insulate all splices with heat shrink tubing.

The finished harness will plug into the GEN1 LITES socket after Drop-In installation

*Wire Colors May Vary But Not Their Placement On The Lamp Boards*

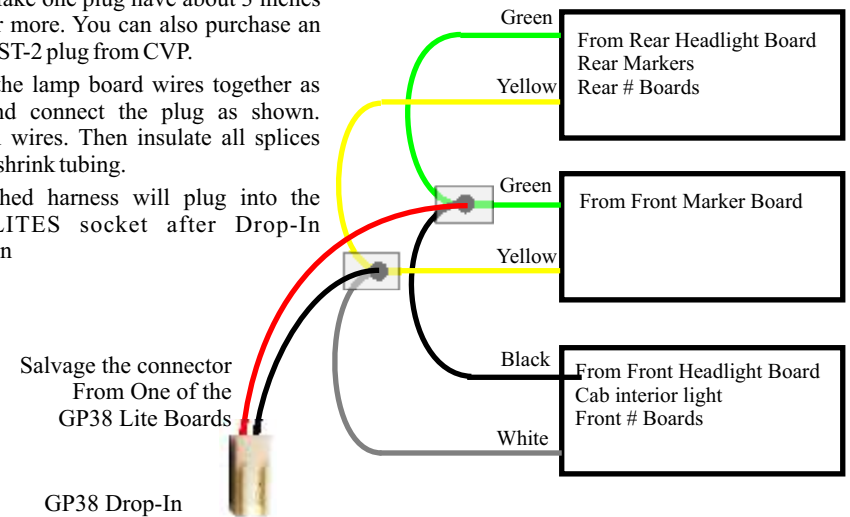

GP38 Drop-In  
GEN1 LITES Header

*FL, MK, RL Sockets Won't Be Used*

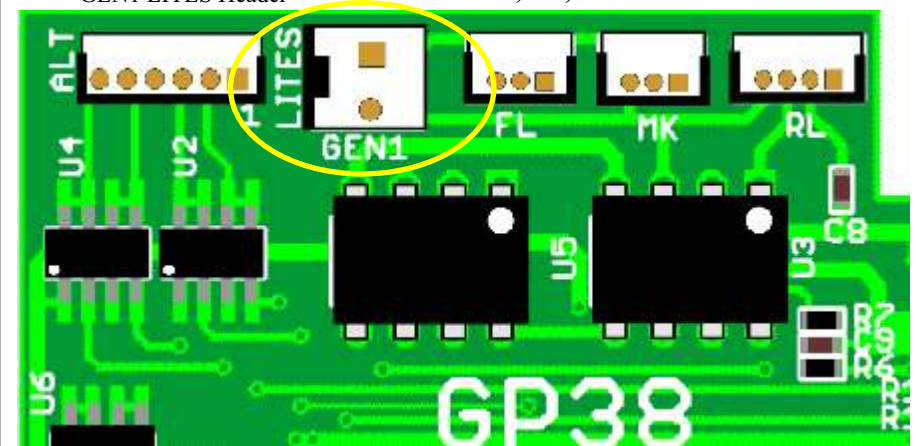

## Enlarge Switch Hole And Mount Battery

### Enlarge Switch Opening In Chassis Floor

Look at the bottom of the Drop-In board. Note the two switches and jack. The switches fit the outside switch holes in the locomotive floor. However, the area for the charging jack needs to be enlarged.

In the picture to the left, the area to be enlarged is outlined by a white box. Use a hobby knife or Dremel tool with a routing bit to enlarge this area so the jack simply drops through. The jack must not bind. When the board is mounted, also verify the chassis mounting bosses are in line with the GP38 Drop-In board's 3 mounting holes. The yellow arrows point at the 3 mounting bosses. When completed, clean away the debris and proceed on to the next step.

### Reattach Rear Truck

With the hole enlarged, now is the time to reattach the rear truck. Feed the wires through the hole in the chassis floor. Do not mount the weight, it will be replaced with the battery pack in the next step.

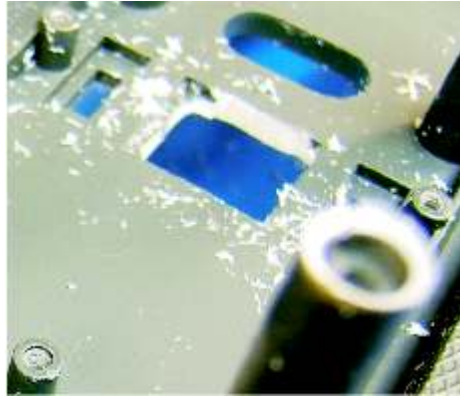
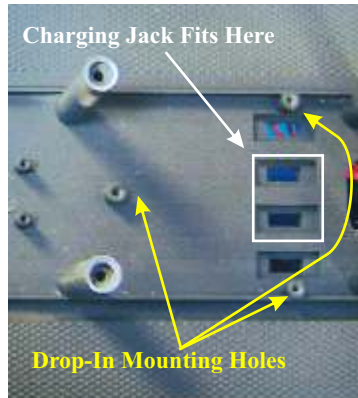

### Battery Mounting

Be sure to reattach the rear truck before mounting the battery. This installation makes use of the standard CVP Lithium battery pack. The small size yet high power capacity makes for a simple installation. The battery replaces the rear weight. The battery is mounted over the rear truck on double stick foam tape.

The two plastic posts that used to hold the weight must be trimmed flush to the floor. Use a pair of flush-cutting wire cutters.

The battery is mounted to the floor using double-sided foam tape. Be sure to apply several layers of tape so the battery does not obstruct or sit on the truck mounting screw. Mount the battery between the posts onto the tape and press down firmly. For added strength, a small dab of hot melt glue can also be used, but keep the glue away from the truck mounting screw.

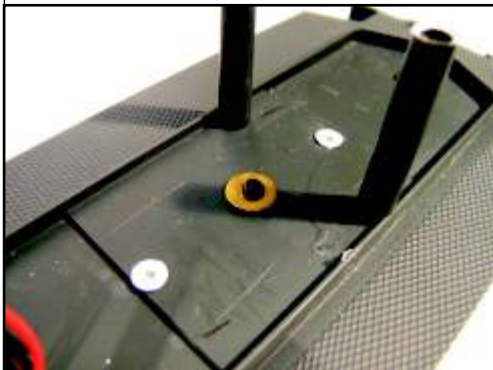

## Speaker And P8 Interface Jack Mounting

In the next step, the fuel tank is fitted with a speaker and the Phoenix P8 sound module interface jack. If you are not using a sound decoder, skip the next two pages.

### P8 Interface Jack Installation

The Phoenix P8 sound module uses a programming jack to connect it to a PC for editing and downloading of sound files. The programming jack is shown installed into the fuel tank. However, it can be mounted anywhere, only limited by the cable length. For fast mounting, use quick-set epoxy or hot-melt glue.

The end of the fuel tank facing the rear truck is where to drill the hole. Put the hole about half way up the tank and favoring one side. This makes it easier to plug in the programming jack. Drill a 5/16 inch hole for the jack. Remove any burrs from around the hole.

The fuel tank walls are too thick for the jack's threads so remove the nut from the jack and discard. Push the small plug and wire through the fuel tank hole. Use either epoxy or hot-melt glue to permanently mount the jack.



### P8 Speaker Mounting

Newer speakers from Phoenix include a two wire plug pre-attached to the speaker. If yours is different, solder the wires to the speaker before mounting it. Hot melt glue is the quickest method to mount the speaker although some people prefer silicone adhesive which takes longer to dry. We like hot-melt glue simply because it is fast.

Center the speaker in the grill opening before gluing.

Place the hot melt glue nozzle into the speaker's corner mounting hole and squirt out a blob of glue. Slowly pull the nozzle from the hole while continuing to dispense glue. This builds up a small glue "post" that holds the speaker securely to the fuel tank. Finally, place a small amount of glue around gaps between the speaker and the mounting area for best sound reproduction.

