

Drop-In Decoder CV List and Original Factory Settings

This page lists all of the configuration variables in one convenient location. The column labeled factory settings is how the decoder is delivered. All CV settings are remembered after the battery is disconnected.

CV #	Factory Setting	Value Range	Description
CV1	3	0-99	1-99 Primary Address
CV2	9	0-255	Motor Starting Voltage MSV
CV3	2	0-255	Motor Acceleration Rate
CV4	2	0-255	Motor Deceleration Rate
CV5	255	0-255	Maximum Motor Voltage Vmax
CV6	128	0-255	Mid-point Motor Voltage Vmid
CV8	135	135	CVP Manufacturer ID
CV11	0	0-255	Loss of Signal Timer (seconds)
CV17	0	0-255	Loco Address Hi-Byte
CV18	0	0-255	Loco Address Lo Byte
CV29	2	0-255	Decoder configuration
CV35	0	0-99	F1 Function Key Action
CV36	0	0-99	F2 Function Key Action
CV37	9	0-99	F3 Function Key [RCOUPLR]
CV38	15	0-99	F4 Function Key Action [DL On]
CV39	1	0-99	F5 Function Key Action [CRUISE]
CV40	3	0-99	F6 Function Key Action [CAB] [E1]
CV41	0	0-99	F7 Function Key Action
CV42	0	0-99	F8 Function Key Action
CV43	4	0-99	F9 Function Key Action [AUX1] [E2]
CV44	2	0-99	F10 Function Key Action [SMOKE]
CV45	5	0-99	F11 Function Key [AUX2] [E3]
CV46	0	0-99	F12 Function Key Action
CV56	0	0-255	Bump Amount
CV57	0	0-127	Bump duration in us
CV59	3	1-15	Headlights Effect Period (x512ms)
CV60	0	0-15	Headlights Mode 0=normal/autorev
CV61	4	0-15	Headlight Front Effect
CV62	4	0-15	Headlight Rear Effect
CV63	0	0-1	Cruise Mode - 0 Norm, 1=Track
CV64	4	1-16	Cruise Track Rate (ms)
CV65	2	1-3	Cruise Track Step Size
CV200	0	0-16	RF Frequency number
CV201	3	1-15	Light Effect Period (x512ms)
CV202	4	0-15	CAB Special Effect [E1]
CV203	4	0-15	AUX1 Special Effect [E2]
CV204	4	0-15	AUX2 Special Effect [E3]
CV205	4	0-15	E4 Special Effect
CV206	0	0-255	E4 Auto-off Timer
CV207	3	0-255	DLites Flash period (x256ms)
CV208	0	0-255	DLites Mode (0=On, 1=Off)
CV209	15	0-255	DLites Flash Timeout (seconds)
CV212	3	0-255	Smoke Timeout (3 minutes)
CV213	8	0-99	Function Key 13 [FCOUPLR]
CV214	0	0-99	Function Key 14 Action
CV215	99	0-99	Function Key 15 [Cruise Off]

CV Value	Function Key Action
0	No Function
1	Activate Cruise Control
2	Smoke Enable
3	Toggle CAB Lite [E1] on/off
4	Toggle AUX1 Lite [E2] on/off
5	Toggle AUX2 Lite [E3] on/off
6	Toggle E4 [not available] on/off
7	Dim Headlights on/off
8	Activate Front Coupler
9	Activate Rear Coupler
10-14	reserved
15	Activate Ditch Lights
99	Deactivate Cruise Control

CV Value	Special Lighting Effects
0	Off 0%
1	Dim 6%
2	Dim 25%
3	Dim 50%
4	On 100%
5	Strato Light
6	Oscillating Light
7	FRED
8	Rotary Dome light 1
9	Gyra Light
10	Mars Light
11	Rotary Dome Light 2
12	Strobe Single Pulse
13	Strobe Double Pulse
14	Reserved
15	Random flicker

CV Value	Cruise Control Mode
0	Normal (cruise off with speed change)
1	Tracking mode (Cruise on with change)

CV Value	Head/Rear Lights Action
0	Normal, autoreverse
1	Normal with rule17
2	Front headlight on always
3	Front headlight on always with rule17
4	Rear headlight on always
5	Rear headlight on always with rule17
6	Front and Rear both on always
7	Front and Rear both on always with rule17
8	Reversed Auto Reverse (Front to Back)
9	Reversed Auto Reverse with rule 17
10-15	reserved

Trouble Reading This Page?
A larger text version starts on page 24.

CV numbers above 200 are new CVs that are not present in older Drop-In decoders

May 2017 r104

NEW!
Updated and Enhanced



Drop-In™ Decoder Users Guide

For The USA-Trains GP7/9 and PA/B Drop-In Decoders

Quick Find Index

Drop-In Decoder Quick Start

- Quick Start: Setting or changing the loco number and frequency 3
- Quick Start: When the train doesn't run - steps to fix the problem 4
- Quick Start - Resetting the Drop-In frequency 4
- Assigning Decoder Actions to throttle function keys - Original factory assignments . 5
- Decoder CV numbers for function key actions. 6

Special Effects Options and Customization

- Customizing smoke generator operations. 7
- Phoenix remote coupler operation 7
- Customizing front and rear headlight operation and appearance 8
- Using optional ALT light drivers. 11
- Ditch light appearance customization and control 12
- Assigning special effects to ALT light outputs 13
- Additional LED hookup options 14

Motion Control Fine Tuning

- Motor control and speed curve fine tuning 15
- Acceleration and deceleration rates 17
- Improving motor starting and slow speed motor control with bumping 18
- Locomotive speed matching tips. 19
- Cruise control operation, options and tips. 20

Tools And Reference Items

- Other CVs not detailed elsewhere in this manual. 21
- Phoenix P8 sound module setup and reference information. 26
- Drop-In decoder CV listing in large type size 25
- Simple troubleshooting tips 28
- Run time and battery charge life. 29
- Drop-In frequency listing, Drop-In electrical ratings. 30
- Warranty and Repair Information 31
- Complete table of all Drop-In decoder CV and original factory settings. Back

Terminology

Throughout this section there will be some terms used with which you might not be familiar. This page lists a few of these and their definition.

“CV#” is the abbreviation for Configuration Variable Number: A CV number is a unique and specific memory location, designated by the “number” into which CV values are stored that control how the decoder operates the locomotive. Rather than spell out Configuration Variable Number 1, we shorten this to CV1. So anytime you see CV1, you will know this refers to the configuration variable number 1, which is the locomotive address.

“CV Value” is the abbreviation for Configuration Variable Value:” A CV value is a number loaded into the specified memory location inside the decoder. This value controls or selects various decoder capabilities. In some cases, the value selects from a table of options such as lighting effects or which throttle key activates a locomotive function. CV values are retained inside the decoder even if the power is disconnected or another throttle is used. Thus the locomotive will operate exactly the same no matter which throttle is used. A complete listing of all CV numbers and values used in the Drop-In decoder are on page 29.

Here is a typical listing of a Drop-In Decoder configuration variable. Each CV description is in the same format. The first line gives the function controlled by the CV number. The specific number follows the textual phrase and this entire line is bold faced. The line immediately following the CV number provides the range and the value in square braces is the original factory setting.

Changing the Locomotive Address **CV1**
Range is 1 to 9999 when using an AirWire throttle [3]

Setting, Loading or Programming CVs: We use these words when discussing changing the operation of the Drop-In decoder. There is nothing difficult or hard to learn about programming CVs. In fact, you aren’t really programming anything - you are simply sending the decoder a number to make it perform in a certain way. In simple terms, you are changing how the decoder works. CV values are sent to the Drop-In decoder using the AirWire900 throttle - nothing else is required.

Service Mode is a method of changing settings within the decoder without regard to the decoders locomotive address. This is commonly used when resetting the decoder back to the original factory settings since you might not know or care what the present decoder address is. The one precaution is that any decoder that is powered up and on the same frequency will “hear” the programming commands and be changed.

OPS Mode is a method of changing settings within the decoder that requires you to first specify the locomotive address. Except for changing the locomotive address, OPS should be used for all settings of the decoder. This is the recommended method since all programming commands and settings, sent by the throttle, affects only the decoder with the correct address. Other decoders, sharing the same frequency, will ignore the programming commands.

Speed Step is the phrase that describes a specific setting for the throttle’s speed control. Although the throttle has 3 different speed step settings (14, 28 and 128), the most common setting is 28. This means that the throttle has 28 different speed steps from step-0 which is OFF, to step-28 which is full speed. Inside the decoder, each speed step is translated into a specific motor voltage. The decoder includes several selectable features with which you can modify how the decoder interprets the throttle speed step which in turn modifies the actual motor voltage.

Just changing the throttle’s operating frequency does not change the Drop-In Decoder.

Product Warranty & Repair Information

Warranty Information

This warranty covers substantial defects in materials and workmanship in the Drop-In decoder.

The Drop-In Warranty does not cover the battery, the battery charger and any attached third party decoders including the Phoenix sound module and its components. These devices are covered by the original manufacturers warranty. Contact them for warranty service.

What This Warranty Does Not Cover

This warranty does not cover any problems which result from improper installation, modifications, battery polarity reversal, improper operation, leaking batteries, excessive battery voltages, excessive motor current draw, connections to 3rd party circuit boards, abuse, accidents, or acts of God such as excessive heat, floods, damage caused by exposure to moisture and rain, lightning, earthquakes, volcanic events, tidal waves or hurricanes.

We do not repair or extend any CVP Products’ warranties to the Phoenix modules. CVP Products does not repair Phoenix sound modules. For questions, repairs and warranty information regarding the Phoenix P8 sound module, you must contact Phoenix directly

Warranty Duration

The coverage of this warranty lasts for 90 days. After this period, standard repair rates apply. Depending on the problem, CVP reserves the right to repair or replace.

Help, Repairs and Returns

If you purchased your Drop-In decoder from one of our AirWire900 dealers, please call them first. They are your best and quickest for answers to questions about G2 decoder. They are also experts in installation and offer such services should they be required.

If you purchased your Drop-In decoder **directly** from CVP Products, you may call the main CVP office number below. If the voice mail system answers, it is either after our normal business hours or we are busy helping other customers. Please leave a message. Be sure to leave your phone number and include the area code, along with your location. Have your instruction manuals available, your locomotive with the Drop-In decoder and a throttle before you call.

Do not send items to us for repair without first obtaining authorization. In many cases, problems are easily solved via phone or email without the need or expense to return items to us. **If we authorize** and request you to return an item, be sure to mark the “Return Material Authorization” (RMA) number on the **outside** of the box. **Items sent without an RMA will be refused and returned at your expense.** You are responsible for all shipping charges.

Please allow 4-6 weeks for completion of the repair.

Expedited repair is available for an additional charge. Call for information

For address and shipping options, please go to the CVP website. Click on the orange box labeled Repair Services at the top of the page. Read and follow all instructions. Failure to follow the instructions will delay your repair.

www.cvpusa.com



Drop-In Frequency Listing

The Drop-In decoder supports all 17 AirWire frequencies numbered 0 to 16. It can be set to any of the available frequencies.

Note - if you are using an older RF1300 throttle, only the first 8 frequencies, from 0 to 7, can be used with Drop-In decoder.

<u>Number</u>	<u>Frequency (MHZ)</u>	<u>Number</u>	<u>Frequency (MHZ)</u>
0	921.37	9.....	924.62
1	919.87	10.....	923.12
2	915.37	11	918.12
3	912.37	12	916.87
4	909.37	13	913.62
5	907.87	14	910.87
6	906.37	15	904.87
7	903.37	16	916.37
8	926.12		

Drop-In Decoder Absolute Maximum Ratings

Maximum Input Battery Voltage	24 Volts DC
Minimum Input Battery Voltage	9 Volts DC
Maximum Motor Output Current - Pulse	Internally Limited ~ 18A peak
Maximum Continuous Motor Output Current	~ 8 Amps at 25°C @15V
Maximum Smoke Generator Current	3.0 Amp
Maximum Lamp Current (all lamp drivers)	1 Amp
Maximum Coupler Pulse Width	7ms
Maximum Coupler Pulse Amplitude	Internally clamped to 15V
FCC ID	X7J-A10040601

All specifications subject to change without notice

Quick Start - Setting Locomotive Number

The “Quick Start” section assumes you have already installed your Drop-In decoder. As delivered from the factory, the Drop-In’s frequency is set for 0 and the locomotive address is 3. Use your T5000 for setting or changing your Drop-In decoder.

When setting locomotive number or address, be sure to turn on the Phoenix P8 decoder so it will be programmed to the same number as the Drop-In decoder. Otherwise the locomotive will move but the sound effects will not be correct.

We use the terms decoder-address, loco-address and loco-number interchangeably. They all mean the same thing.

1. Switch On Both the Drop-In and the Phoenix P8. The decoder’s green power LED will glow brightly indicating power is connected. Note, the decoder’s LEDs may not be visible in your locomotive. If so, just ignore the comments about the LEDs being on or off but do follow the instructions in sequence.

2. Set the throttle to frequency 0. When the throttle is turned on and set to the proper frequency, the decoder’s red GP LED will be on steady. If the red LED is not on, then your throttle’s frequency does not match the decoder’s frequency. Do not proceed until both the red and green LEDs are on.

3. Press the green menu key twice and then push the number 4. This activates the SVC PROGRAM application (app).

4. Push the 1 key followed by the ENT key which selects the address CV which is 1.

5. Key in the desired loco number and then ENT. The range is 1 to 9999. The address must be unique. The loco’s cab number is always a good idea. Address 0 is not allowed.

6. Push the red ESC key to exit the SVC PROGRAM app.

Now, set your throttle to the new number and confirm the locomotive moves. You can change this number at any time.

Quick Start - Changing Decoder Radio Frequency

To use this procedure, the current frequency used by the decoder must be known. If this is your first use of the Drop-In, the original factory setting of frequency number 0 is in use. There are 17 available frequencies numbered from 0 to 16. Any frequency can be assigned to the Drop-In decoder.

1. Switch On Both the Drop-In and the Phoenix P8. The decoder’s green power LED will glow brightly indicating power is connected. Note, the decoder’s LEDs may not be visible in your locomotive. If so, just ignore the comments about the LEDs being on or off but do follow the instructions in sequence.

2. Set the throttle to frequency 0. When the throttle is turned on and set to the proper frequency, the decoder’s red GP LED will be on steady. If the red LED is not on, then your throttle’s frequency does not match the decoder’s frequency. Do not proceed until both the red and green LEDs are on.

3. Press the green menu key twice and then push the number 4. This activates the SVC PROGRAM application (app).

4. Key in 200 followed by the ENT key which selects the frequency CV which is 200.

5. Key in the desired frequency number and then ENT. The range is 0 to 16. Keep a record of what you have loaded into the decoder.

6. Push the red ESC key to exit the SVC PROGRAM app.

Now, set your throttle to the new frequency and the desired loco number and confirm the locomotive moves. You can change the frequency at any time.

Optional: Push the LOCO MEM key twice. This will store the loco-number and the loco frequency in the throttle memory.

Quick Start - When The Train Doesn't Run

There may come a time when the decoder no longer responds to what you believe is the correct frequency, or you don't know its address or you've changed the light settings and have lost track of what's what. Don't despair! The solution is easy. Just reset the Drop-In decoder back to the original factory settings. **Note: this procedure will not reset the P8 sound module. But when you load a new loco number, the P8 will also accept the new number and the two will work together.**

Beware of Lurking Locomotives When Using SERVICE PROGRAM Mode

The SVC PROGRAM app broadcasts commands that can be heard and understood by any other decoder sharing the same frequency as the intended decoder. If another decoder receives the command, it too will be programmed. Play it safe and make sure to turn off all power switches on locomotives not being programmed.

Resetting Decoder to Original Factory Settings of Loco Number 3 and Frequency 0

1. Turn off all AirWire throttles. This is very important since it is the absence of a throttle signal, plus turning the power off and then back on (a power cycle), that allows the decoder to temporarily jump to a specific known frequency, which is frequency 0.
2. Switch off the decoder if it was powered on.
3. Switch on the decoder and **wait** at least one minute. At the end of the one minute, the decoder will chirp 5 times. At the end of the chirps, the decoder will be temporarily on frequency 0.
4. Now **turn** on your throttle. Set the throttle to frequency 0. The loc number doesn't matter.
5. Push MENU twice and then push 4 for SVC PROGRAM.
6. Push 8 and ENT for CV8.
7. Push 1, 3, 5 and push ENT to send the factory reset value of 135. The decoder will chirp when the command is accepted.
8. Turn off, and then turn back on the Plug-In decoder. The decoder is now set to address 3 and frequency 0. All of the lighting effects, function key assignments and modes are set to their original factory values. Remember that the P8 sound module has not been changed in any way. To match sound and motion, you must now change the loco number as described on page 3.

This completes the factory reset procedure.

Quick-Start - Resetting The Drop-In Frequency

There may come a time when your locomotive no longer responds to what you believe is the correct frequency, or you can not remember the correct frequency. Here's how to reset the frequency. But, this procedure **WILL NOT** change or reset the locomotive number or any changes made to the decoder.

Step 1 Turn off all AirWire throttles. This is very important since it is the combination of the absence of a throttle signal, plus a decoder power-cycle (turning the decoder's power off and then back) that allows the decoder to temporarily jump to frequency 0 where you can set a new frequency.

Step 2 Turn off the Drop-In decoder if it was powered on.

Step 3 Turn on the Drop-In decoder and wait at least one minute. Do not turn on any throttles during this time. At the end of one minute, the decoder will chirp 5 times. Wait for the chirps to end then move to the next step.

Step 4 Turn on your throttle, and set it to frequency 0.

Step 5 - Use SVC PROGRAM to set CV200 to the desired frequency. The locomotive address does not matter when using SERVICE PROGRAM mode. Be sure and make a note of the new frequency.

Run Time And Battery Charge Life

How Long Do The Batteries Last?

This is a very common question that does not have a simple answer. This is because the answer depends on many factors such as: type of railroad, locomotive condition, temperature, how the railroad is operated, how many cars are pulled, how many hills and so on.

A rough idea of the battery life can be determined by dividing the battery rating which is in Amp-hours (Ahr) by the motor current. For example, the CVP recommended battery pack is rated at 4.4 Amp-hours. In other words, the battery will last about 1 hour if the locomotive pulls 4.4 Amps. Fortunately, the locomotive motors will seldom get close to that value. Under normal operating conditions, you can expect up to 3 or 4 hours from one charge.

The Motor Is The Primary Battery Drain

When running on straight and level track at about half of top speed, the twin motors of the USA-Trains will pull between 1.0 and 1.5 amps. There is also a brief but high current draw when the locomotive initially begins moving.

Locomotive speed also affects battery drain. The faster the locomotive speed, the faster the battery drain. Slow down and your battery will last longer.

If the speed is constant, but more cars are added, the faster the battery drain. But there is a limit to the number of cars that may be pulled.

Lugging down the motor by forcing to haul too many cars up the hill will very quickly drain the battery. Instead, use multiple locomotives or helpers. Your batteries will last much longer. Also, slower running decreases the battery drain. You can also limit the number of cars.

Smoke Generator And Battery Drain

There is one other item that can quickly drain the battery - the smoke generator. The little smoke generator consumes about a half amp when running. Fortunately, the Drop-In decoder has a built in timer that shuts off the generator after about 2 minutes. This will insure that it will automatically turn off should you forget. So, unless you keep retriggering the generator, its current draw will be minimized.

Lighting And Battery Drain

Each USA-Trains locomotive has different light configurations. For example, the GP30 use all incandescent bulbs where as the SD70MAC uses mostly LEDs. So if your locomotive has lots of incandescent bulbs, these will consume as much as a half amp of current. To maximize battery life, turn off all unused lights or lights that are not easily seen. For example, the number-board lights will hardly be noticeable in broad daylight - so turn them off and save a bit of power..

Recharging The Battery

When you are finished using the locomotive, turn off both Drop-In power switches and plug in the charger. If the power switches are not off, the battery can not be charged. Check that the charger indicator light is red which says it is charging. The charger will shut off automatically and the indicator will change to green when the battery is fully charged.

Once the battery is charged, you can unplug the charger. However, there is no harm leaving the charger plugged into the locomotive.

The Drop-In decoder power switches must be in the off position in order to recharge the battery.

Simple Troubleshooting Tips

These tips assume the locomotive has been operating normally for a while.

Locomotive Stops Running - But Resumes Running After A Short Rest

This is likely to be caused by overheating of the motor power drivers. If the drivers overheat, they will automatically shut down and stay off until the power is cycled off, then back on. There is no warning buzzer when this occurs. There is no harm to the decoder, but the drivers need additional ventilation.

Motor Runs For Short Period Then Stops

There are several possible reasons for this - let's start with the easy one first. Make sure the throttle is turned on, is set to the proper frequency and locomotive address. Make sure there isn't an interfering throttle somewhere in the area. Remember that each throttle must be on a different frequency. If all of these are OK, try another throttle. If it too doesn't work, then the cause could be the locomotive.

Reconnect the charger and verify that the charger indicator is visible and green. If the light is red, then the battery is depleted and needs to be recharged.

It is possible that a momentary overload tripped the battery or motor driver protection circuits. Cycle the decoder power off then back on and try again. If the problem persists, there may be a problem with one or both of the locomotive motors. There is also a possibility of a faulty battery. Substitute a different battery and try again.

Another possible cause is a bad battery. Batteries don't last forever plus their actual life can be drastically shortened if the proper charger is not used. Try another battery to verify if the battery is the cause of the problem.

Train Stops When It Is Far Away

This is an easy one. You need to set the Drop-In decoder "loss of signal" timer, CV11, to a value of 0. Any other value and the locomotive will come to a halt when the throttle signal is gone and the timer has expired. The original factory value is 0 although it might have been inadvertently changed.

Throttle Loses Control When Locomotive Is Far Away

This is just the normal limitation of the radio system. Do not expect the throttle to control the train when it is a thousand yards away. If your railroad is in a large loop, leave the throttle on its original speed setting and let the train come back to you. Once the train is within range, the throttle will once again regain control. Be sure and set the loss of signal timer, CV11, to 0.

Horn Won't Stay On When F2 is Pushed And Held

This is usually caused by a combination of a noisy motors and distant operation and is not actually a problem. Instead, it is an automatic feature of the Drop-In decoder. There is nothing more annoying than a locomotive horn that is stuck on. The Drop-In decoder includes a special feature that prevents stuck horns. If for any reason, the decoder stops receiving throttle commands, and the last command was horn ON, then it will automatically issue a horn OFF command after a preset amount of time.

Limited Range

For best performance, the whip antenna should be vertical. Keep all power wiring away from the antenna such as the battery and motor wires. Also, brand new locomotives tend to create a lot of motor interference since the motor brushes are new and not well seated. Range will improve as the locomotive's motor brushes seat better.

Although it is not easy to do, consider adding motor brush noise suppression capacitors to the motors right at the motor's terminals. A 0.1uF ceramic capacitor rated at 50V should be used.

Finally, lower the battery voltage. The Drop-In decoder is optimized for 14.8 volt Lithium batteries. Higher battery voltages generate much more motor noise.

Poor Reception Or Interference

The AirWire system operates in an unlicensed band shared by many other transmitters. These transmitters can and will create interference, intermittent throttle operation or complete failure of one or more of your throttle's frequencies. The sources of these external interfering signals can be from your own home or from adjacent homes and businesses. They can also be from other wireless throttles and controllers. If you find a strong interfering signal on one or more of your frequencies, don't use those frequencies. Simply select another, different frequency.

Assigning Throttle Function Keys To Decoder Actions

Use this step-by-step sequence to change what the decoder does when it receives a throttle function key command.

The Drop-In decoder has many memory locations so we use the term CV# where # is a specific memory location. So CV40 means Drop-In decoder memory location number 40. The value stored at this location dictates what the decoder does when it receives a throttle's function key command.

Always start by thinking through what you want your throttle to do to the Drop-In decoder. For this example, here's what is wanted:

“On the throttle, I want the throttle's 6 key to turn on the smoke generator.”

Notice the underline of the important items: which throttle key is to be used, and what the decoder action will be when that key is pushed. For this example, F6 is the throttle's 6 key. Now you are ready to set the Drop-In decoder so that it performs the desired action when F6 is pressed.

Step 1: Find F6 in the Function Key Assignment table on the next page.

From the table, the Throttle Function 6 action is defined by the value in CV40.

Step 2: Find the desired action in the action table and note the value. This will be what is stored in CV40.

For this example, since the smoke generator is to be toggled, which means turned on and off, the CV value of 2 is to be used.

Step 3: Turn on the Drop-In decoder's power. Set your throttle to the decoder's frequency and locomotive address if it has not yet been set. This is very important since if either the frequency or the locomotive address is wrong, the decoder will not hear the throttle's OPS PROGRAM command.

Step 4: SVC PROGRAM CV40 to a value of 2. The decoder will chirp indicating it heard and accepted the command. Escape out of OPS PROGRAM and verify that the decoder's action is correct when the 6 key is pressed on the throttle.

This same sequence is used to assign or change what the function keys will do.

Original Factory Settings For Functions and Actions

Original Factory Settings For Throttle Function Key Actions			
Key	CV#	VAL	Action
0	na	na	Toggle Headlights On/Off
1	CV35	0	na
2	CV36	0	na
3	CV37	9	Activate Rear Coupler
4	CV38	15	Activate Ditch Lights
5	CV39	1	Activate Cruise Control
6	CV40	3	Toggle Cab Light On/Off
7	CV41	0	na
8	CV42	0	na
9	CV43	4	Toggle AUX1 On/Off
*0	CV44	2	Toggle Smoke Off
*1	CV45	5	Toggle AUX2 On/Off
*2	CV46	0	na
*3	CV213	8	Activate Front Coupler
*4	CV214	0	na
*5	CV215	99	Deactivate Cruise Control

Except for F0, any function key can be reassigned to any action you wish.

In this table, "na" means not assigned.

*n means to push the * key first followed by the number. This is how the function keys above 9 are entered.

Programming Methods

There are two types of throttle programming modes: Service Programming (SVC) and Operation Programming (OPS).

If SVC Programming is used, no loco number is needed. However, any loco turned on and using the same frequency also **WILL BE** programmed.

If OPS Programming is used, a loco number must be specified. Because the loco number must match, the OPS Programming mode is the safest mode to use when there are a large number of locos lurking in the area.

Decoder CV Numbers For Function Key Activation

The table to the right lists the CV number assigned to each of the throttle function keys.

The CV number is the decoder memory location that holds the value. The value determines what the decoder does when the function command is received.

The new Drop-In decoder supports more throttle function keys than our previous decoders.

The extra functions provide additional throttle control of the new Drop-In decoder features such as coupler activation.

Note: Only the T5000 throttles or later models offer throttle functions above 12.

Function Key Assignment	CV#
F1 Function Action CV	CV35
F2 Function Action CV	CV36
F3 Function Action CV	CV37
F4 Function Action CV	CV38
F5 Function Action CV	CV39
F6 Function Action CV	CV40
F7 Function Action CV	CV41
F8 Function Action CV	CV42
F9 Function Action CV	CV43
F10 Function Action CV	CV44
F11 Function Action CV	CV45
F12 Function Action CV	CV46
F13 Function Action CV	CV213
F14 Function Action CV	CV214
F15 Function Action CV	CV215

Decoder Actions

This table shows all of the possible decoder actions that can be triggered when a throttle function key is pressed.

It is OK for the same action to be assigned to multiple function keys.

As an example, if you want the 1 key to turn on the CAB light, the CV value of 3 [Toggle CAB light on/off] is assigned to CV number 35 (F1 Function Action CV).

Not all actions are available on all Drop-In decoders. For example, E4 is not available on the GP7/9, PA/B or S4 locomotives.

The available actions for a specific Drop-In decoder are listed in the Drop-In Decoder Installation Manual for your locomotive.

CV Value	Function Key Action
0	No Function
1	Activate Cruise Control
2	Smoke Enable
3	Toggle CAB Lite [E1] on/off
4	Toggle AUX1 Lite [E2] on/off
5	Toggle AUX2 Lite [E3] on/off
6	Toggle AUX3 [E4] on/off
7	Dim Headlights on/off
8	Activate Front Coupler
9	Activate Rear Coupler
10-14	reserved
15	Activate Ditch Lights
99	Deactivate Cruise Control

See the back cover page of your Drop-In Installation Manual for supported CV actions

Drop-In Decoder CV Value Lists

CV Value	Special Lighting Effects
0	Off 0%
1	Dim 6%
2	Dim 25%
3	Dim 50%
4	On 100%
5	Strato Light
6	Oscillating Light
7	FRED
8	Rotary Dome light 1
9	Gyra Light
10	Mars Light
11	Rotary Dome Light 2
12	Strobe Single Pulse
13	Strobe Double Pulse
14	Reserved
15	Random flicker

CV Value	Cruise Control Mode
0	Normal (cruise off with speed change)
1	Tracking mode (Cruise stays on with change)

CV Value	Head/Rear Lights Action
0	Normal, autoreverse
1	Normal with rule17
2	Front headlight on always
3	Front headlight on always with rule17
4	Rear headlight on always
5	Rear headlight on always with rule17
6	Front and Rear both on always
7	Front and Rear both on always with rule17
8	Reversed Auto Reverse (Front to Back)
9	Reversed Auto Reverse with rule 17
10-15	reserved

Drop-In Decoder Configuration Variables List

continued from previous page

CV63	0	0-1	Cruise Mode - 0 Norm, 1=Track
CV64	4	1-16	Cruise Track Rate (ms)
CV65	2	1-3	Cruise Track Step Size
CV200	0	0-16	RF Frequency number
CV201	3	1-15	Light Effect Period (x512ms)
CV202	4	0-15	Cab Special Effect [E1]
CV203	4	0-15	AUX Special Effect [E2]
CV204	<i>na</i>	<i>na</i>	<i>not available [E3]</i>
CV205	4	0-15	Smoke Special Effect [E4]
CV206	120	0-255	Smoke Timer 0=manual
CV213	8	0-99	Function Key 13 [FCOUPLR]
CV214	0	0-99	Function Key 14 Action [<i>unassigned</i>]
CV215	99	0-99	Function Key 15 [Deactivate Cruise]

Drop-In Decoder CV Value Lists

CV Value	Function Key Action
0	No Function
1	Activate Cruise Control
2	Smoke Enable
3	Toggle CAB Lite [E1] on/off
4	Toggle AUX1 Lite [E2] on/off
5	Toggle AUX2 Lite [E3] on/off
6	Toggle E4 on/off
7	Dim Headlights on/off
8	Activate Front Coupler
9	Activate Rear Coupler
10-14	reserved
15	Activate Ditch Lights
99	Deactivate Cruise Control

Customizing Smoke Generator Operation

The USA-Trains Locomotive's smoke generators are the standard resistor heater and fluid reservoir. Activating the smoke generator with F10, turns on the heater, heats up the fluid which changes to visible smoke. The smoke generator control may be moved to a different function key if desired.

Allow up to a minute for smoke to begin. Don't overfill the reservoir or it may never smoke.

The Drop-In Has A Built-In Programmable Timer For The Smoke Generator Shut-Off. The shutoff time can be set in seconds from 0 to 255 minutes. Earlier versions of the Drop-In decoder were limited to just 255 seconds. The new original factory setting is 3 minutes. After the timer has expired, the decoder automatically turns off the smoke generator. It can be re-triggered by pushing the F10.

CV212 sets the time delay and has a range of 1 to 255 minutes. If CV212 is set to 0, the timer is disabled and the smoke generator can be manually controlled. Once it is turned on with F10, only another push of F10 will turn it off. This is not a recommended setting since it might cause the heater to burn out once the fluid is gone. The default setting 3 minutes.

SMOKE On-Time Duration Timer **CV212**
Range is 0-255 [3]

Other Uses For Smoke Driver

The smoke driver can be used to turn other devices on or off. Think of it as a SPST toggle switch to battery minus. The load connects between the driver and battery plus. Relays and solenoids are good examples of devices suitable for the smoke driver. The maximum load is 3 amps. The relay or solenoid voltage rating must match the battery voltage plus or minus 2 volts. If using a 14.8V battery, a 12V relay will work. Be sure and use the protection diode, wired as shown to protect the smoke driver transistor.

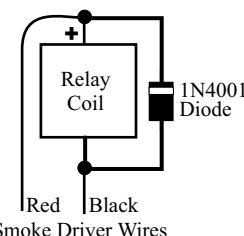

Optional Phoenix Coupler Operation

The Drop-In series decoder includes built-in drivers and matching sockets for two Phoenix "solenoid" style couplers. These are labeled FCP for the front coupler and RCP for the rear coupler. Function key F3 has the factory setting of activating the rear coupler. Function key F13 has the factory setting to activate the front coupler. Coupler activation can be reassigned to other throttle function keys, especially if your AirWire throttle doesn't support more than 12 functions.

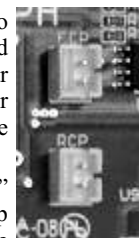

Battery Voltage Range is 8 to 24 volts. However, at lower voltages, the solenoid "snap" will be somewhat weaker and might not release if there is any tension present. The snap time is optimized for the CVP 14.8V battery. However, the coupler will reliably operate from 8 to 24 volt batteries.

Coupler Operation

The Phoenix coupler must not have tension on the knuckle or it will not release. Thus it is called a slack-type coupler. There must be slack in the coupler so the knuckle releases when activated. So back up a bit to release the tension and then activate the coupler.

To re-couple, make sure the knuckle is open and firmly back into the car to be coupled. The knuckle will lock closed upon contact.

Coupler Mounting

Coupler mounting is your biggest challenge. Although originally designed for truck mounting, the coupler should be body mounted for better operation. If you find a good way to mount the coupler on the body, be sure and take pictures and share with us and Phoenix.

Couplers, connecting cables and usage guidelines can be found and ordered on the Phoenix Sound Website. Contact them with questions about their couplers.

www.phoenixsound.com

Customizing Headlight Operation Mode

There are 4 CVs that govern how a headlight operates. These 4 CVs allow headlights to be configured to match your favorite prototype railroad or you can establish your own style.

Each of the CVs will be described followed by various tables of effects that can be assigned to the headlights.

Summary Table For All Headlight Effect CVs

CV #	Factory Setting	Value Range	Description
CV59	3	1-15	Headlights Effect Period (x512ms)
CV60	0	0-15	Headlights Mode 0=normal/autorev
CV61	4	0-15	Headlight Front Effect
CV62	4	0-15	Headlight Rear Effect

The Drop-In Decoder allows the front headlight and the rear backup light to operate in several different modes. The different modes control if and when the headlight dims and how the headlight and backup light operate. For example, the front headlight and the rear headlight can both be on at the same time or the front headlight can remain on, independent of the direction of travel. How the headlights behave are determined by the value stored in CV60.

Headlight Mode **CV60**

Range is 0-15. [0]

As with all setup options, the desired operating mode is selected from a CV value table and the appropriate number is stored in CV60 of the decoder's memory. The mode can be changed at any time.

CV60 only affects the headlight and the backup light operating modes. It has no effect on any other locomotive light.

Special lighting effects can be applied to the front and rear headlights and are described on the next page.

Normal Operation: The front headlight turns on at full brightness and the selected effect, if any, is applied. Normal operation also includes default headlight autoreverse. Autoreverse means that the front headlight is on when the throttle is set for the forward direction and off when set for the reverse direction. Conversely, when using autoreverse, the rear headlight light is off when in the throttle is set for the forward direction and on when set for reverse.

Lights Are Normally Off

When power is first applied to the decoder, all lights are initially off.

Head Lights Are Turned On With F0

To turn headlights on or off the headlights, push the 0 key on your throttle.

Drop-In Decoder Configuration Variables List

CV #	Factory Setting	Value Range	Description
CV1	3	0-99	1-99 Primary Address
CV2	9	0-255	Motor Starting Voltage MSV
CV3	2	0-255	Motor Acceleration Rate
CV4	2	0-255	Motor Deceleration Rate
CV5	255	0-255	Maximum Motor Voltage Vmax
CV6	128	0-255	Mid-point Motor Voltage Vmid
CV8	135	135	CVP Manufacturer ID
CV11	0	0-255	Loss of Signal Timer (seconds)
CV17	0	0-255	Loco Address Hi-Byte
CV18	0	0-255	Loco Address Lo Byte
CV29	2	0-255	Decoder configuration
CV35	0	0-99	F1 Function Key Action
CV36	0	0-99	F2 Function Key Action
CV37	9	0-99	F3 Function Key [RCOUPLR]
CV38	0	0-99	F4 Function Key Action [none]
CV39	1	0-99	F5 Function Key Action [CRUISE]
CV40	3	0-99	F6 Function Key Action [CAB]
CV41	0	0-99	F7 Function Key Action
CV42	0	0-99	F8 Function Key Action
CV43	4	0-99	F9 Function Key Action [AUX]
CV44	6	0-99	F10 Function Key Action [SMOKE]
CV45	5	0-99	F11 Function Key [none]
CV46	0	0-99	F12 Function Key Action
CV56	0	0-255	Bump Amount
CV57	0	0 - 127	Bump duration in us
CV59	3	1-15	Headlights Effect Period (x512ms)
CV60	0	0-15	Headlights Mode 0=normal/autorev
CV61	4	0-15	Headlight Front Effect
CV62	4	0-15	Headlight Rear Effect

continued on next page

Phoenix P8 Sound Module Function Key Assignments

The table of throttle function key assignments to sound effects works well for most P8 diesel engine installations. You may download a CVP diesel configuration file from the Phoenix website that sets up these and other features in the P8 sound module. You must use the P8 computer interface to make these assignments. These are not programmable from the throttle. However, if you don't like our recommend settings, feel free to change them and experiment - you can't hurt anything.

Function Key Assignments	Sound	Drop-In Motion
Function F0	<i>not available</i>	Toggle Headlight
Function F1	Bell	<i>none</i>
Function F2	Manual Horn	<i>none</i>
Function F3	Coupler	Activate Rear Coupler
Function F4	Crossing Horn	<i>none</i>
Function F5	All Aboard	Activate Cruise Control
Function F6	Compressor Startup	Toggle Cab Light
Function F7	Volume Up	<i>none</i>
Function F8	Volume Down	<i>none</i>
Function F9	Dynamic Brakes	<i>none</i>
Function F10	Brake Release	Activate SMOKE
Function F11	Air Pop Valve	<i>none</i>
Function F12	Shutdown	<i>none</i>
Function F13	<i>not available</i>	Activate Front Coupler
Function F14	<i>not available</i>	<i>none</i>
Function F15	<i>not available</i>	Deactivate Cruise Control

Shared CVs Between P8 And Drop-In Decoder

P8 Sound Module and Drop-In Decoder Have Shared CVs

The P8 shares three CV numbers with the NW2 Drop-In decoder. These three CVs perform the same function in both decoders - they set the decoder's locomotive address.

The AirWire Throttle automatically programs these three CVs when you program the locomotive address. Except in rare instances, both the P8 and the Drop-In decoders are programmed at the same time and to the same address.

If you want to an address of only one decoder, turn off the power switch of the decoder that is not to be changed. Then use SVC PROGRAM to program the decoder.

Except for the address CVs, no other CVs are shared between the P8 and the Drop-In decoder. You may issue OPS or SVC programming commands to the NW2 without fear of affecting the P8.

Shared CV Table	P8 Use	NW2 Motion Use
CV1	Short Address	Short Address
CV17	Long Address	Long Address
CV18	Long Address	Long Address

Customizing Headlight Operation Mode *continued*

Auto-Dim Headlight Mode [rule 17]: When this option is selected, the headlight automatically dims when the throttle is set to zero speed. When dimmed, the headlight glows at a reduced brightness and without any special effects. Turning up the speed knob automatically restores the headlight and its assigned lighting effect to full brightness. This feature is optimized for white LEDs. Locomotives that use incandescent bulbs for headlights may appear very dim when using this feature.

CV Value	Head/Rear Lights Mode (Action)
0	Normal, autoreverse
1	Normal with rule17
2	Front headlight on always
3	Front headlight on always with rule17
4	Rear headlight on always
5	Rear headlight on always with rule17
6	Front and Rear both on always
7	Front and Rear both on always with rule17
8	Reversed Auto Reverse (Front to Back)
9	Reversed Auto Reverse with rule 17
10-15	reserved

Special Headlight Effects

There are a variety of special lighting effects that can be applied to the Drop-In decoder's headlights. To apply an effect, determine which headlight is to have the effect, front or rear or both, find the desired effect in the effects table, note the CV value and then load this value into the CV 61 or 62 or both.

Front Headlight Effect **CV61**
Range is 0-15 [4]

Rear Headlight Effect **CV62**
Range is 0-15 [4]

Headlights Effect Timing Rate **CV59**
Range is 1-15 [3]

Lighting effects that offer a repeating pattern can have the rate or speed at which the pattern is repeated. The rate is based on the value set into CV59. This CV controls the rate of a repeating pattern. Examples of repeating patterns that apply to light effects are Mars and Gyra lights. The period range is 1 to 15 and is in units of 1/2 second. For example a period value of 2 gives a repeating pattern of about once per second. Bigger numbers represent slower repeat times. The period CV does not apply when the selected effect is either full bright, dim or random flickering. A value of 0 shouldn't be used although if you accidentally enter 0, the decoder will automatically change it to a value of 1.

The table on the next page summarizes the lighting effects and the CV value to activate the lighting effect. Also shown is whether the timing rate applies to these effects. All of these effects are optimized for LED lighting but work with incandescent bulbs too.

At any time, you may issue a reset to set all of the decoder CV values back to their original factory settings - don't be afraid to experiment. Nothing can be harmed or damaged.

Special Headlight Effects *continued*

CV Value	Special Lighting Effects
0	Off 0%
1	Dim 6%
2	Dim 25%
3	Dim 50%
4	On 100%
5	Strato Light
6	Oscillating Light
7	FRED
8	Rotary Dome light 1
9	Gyra Light
10	Mars Light
11	Rotary Dome Light 2
12	Strobe Single Pulse
13	Strobe Double Pulse
14	Reserved
15	Random flicker

Multi-Unit Consist Lighting Tip

Here is how to set up a two unit consist that uses the headlight mode feature to automatically turn on the proper headlight depending on the direction of travel.

Multi-Unit Consist With Directional Lighting For Leading and Trailing Units

In this example, there are 2 locomotives that are consisted together. The locomotives all face the same direction. The desire is for the leading unit to have the front headlight on, when in the forward direction and its rear headlight off when going in the reverse direction. For the trailing unit, only the rear headlight is on when going in the reverse direction and the front headlight is off when going forward. The CV numbers and their values are shown for the leading and trailing locomotives. Both locomotives share the same frequency but can have different loco numbers.

Leading Locomotive	CV#	Value	Trailing Locomotive	CV#	Value
Headlight Mode	CV60	0	Headlight Mode	CV60	0
Front Headlight Effect	CV61	4	Front Headlight Effect	CV61	0
Rear Headlight Effect	CV62	0	Rear Headlight Effect	CV62	4

Recommended Phoenix P8 Configuration and Setup

P8 Configuration and Setup Recommendations

These modifications are done with the Phoenix programming software and their PC interface hardware. Only those items that are different than the standard settings are shown. For example, the automatic tooting of the horn and ringing of the bell are turned off. If you like that effect, then don't change the original setting. Once all the changes have been loaded into the P8 module, save the configuration file under the locomotive number before disconnecting the computer interface.

Volume Levels	Was	Recommended
Fwd Horn Volume	90%	0
Rev Horn Volume	100%	0
Stopping Horn Volume	100%	0

Numeric Settings	Was	Recommended
Stopping Bell Speed	20	0
Stopping Bell Duration	8	0
Startup Bell Duration	4	0
Triggered Bell Duration	6	0
Auto Bell Speed Limit	40	0
Bell Holdoff	30	0

Selection Settings	Was	Recommended
Chuff Averaging	Disabled	Disabled
Speed From DCC	Disabled	Disabled
MTS Detection	Enabled	Disabled

Trigger Terminal Assignments	Was	Recommended
Trigger 1	Chuff Pin	<unassigned>
Trigger 2	Manual Whistle Pin	<unassigned>
Trigger 3	Bell Pin	<unassigned>
Trigger 4	Blowdown Pin	<unassigned>
Trigger 5	Station Pin	<unassigned>
Aux Board 1/T1	Drifting Pin	<unassigned>
Aux Board 1/T2	Water Fill Pin	<unassigned>
Aux Board 1/T3	Coal Load Pin	<unassigned>
Aux Board 1/T4	Coupler Pin	<unassigned>
Aux Board 1/T5	Crossing Whistle Pin	<unassigned>
Aux Board 1/T6	<unassigned>	<unassigned>

Free P8 CVP Diesel Config File From Phoenix

You may download a CVP diesel configuration file from the Phoenix website for the above features as well as the function key assignments for the P8 sound module.

www.phoenixsound.com/support/download.html

CVP Products does not provide customer support for the P8 sound module. Please contact Phoenix Sound Systems directly via email or phone.

(800) 651-2444 Email:
phoenixsound@phoenixsound.com

Phoenix P8 Sound Module Hookup

This is the Phoenix P8 hookup diagram. The wires are somewhat stiff and fragile. Don't subject them to a lot of unnecessary flexing.

If not using a P8 speaker, cut off the connector on the two brown speaker wires and solder the wires directly to the speaker.

The sockets are polarized and can only be completely inserted when oriented correctly.

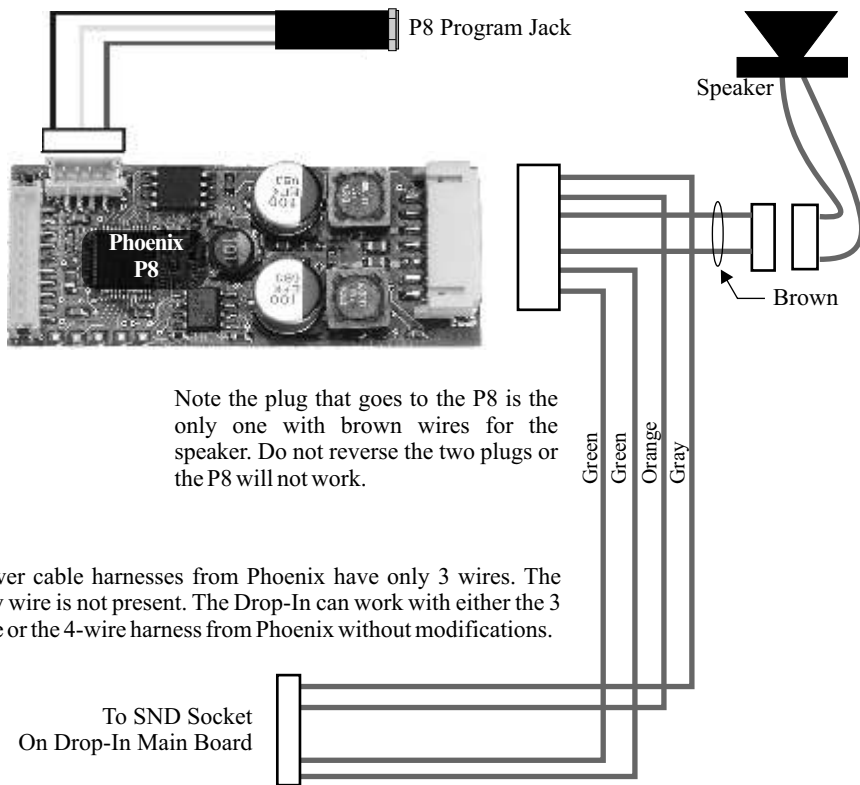

Note the plug that goes to the P8 is the only one with brown wires for the speaker. Do not reverse the two plugs or the P8 will not work.

Newer cable harnesses from Phoenix have only 3 wires. The gray wire is not present. The Drop-In can work with either the 3 wire or the 4-wire harness from Phoenix without modifications.

P8 Power Switch

The Drop-In decoder has a dedicated power switch for the P8. The P8 power switch is independent of the Drop-In decoder power switch. When turned on, the P8 is connected directly to the battery. The P8 can be powered while the Drop-In decoder is not. Don't forget this fact when you turn the sound volume down low or off. Even if off, the P8 draws power from the battery and it will not automatically turn off. Always use the power switch to shut off the P8.

P8 Address Setup

The P8 is programmed at the same time as the Drop-In decoder address is programmed but the P8 must be powered on for this to occur. If for any reason, you think the P8 or the Drop-In might not be on the same address, just reprogram the decoder's locomotive address, CV1, from the throttle.

P8 Sound Options Programming

The P8 sound options can only be programmed from a PC using programming adapter and software available from Phoenix. See their website for more information.

P8 Technical Support

CVP does not provide technical support for the Phoenix P8 sound module. If you have any troubles with your P8, contact Phoenix for help and support. They will be happy to help you out.

Using Optional ALT Light Drivers

The Drop-In decoder has 4 extra light drivers available at the small white socket labeled ALT. The picture shows the GP7/9-PA/B socket. The matching cable with plug is available separately. Order part number ALT-6.

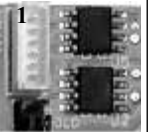

Two of the light drivers are paired together for use as ditch light drivers. There are extra CVs that control the operation mode, flash rate and time out. Two more light drivers are available for any lighting task required. Each one can have a special effect.

LED Limit Resistors

All of the ALT light drivers are designed to use efficient, cool and bright light emitting diodes LED. However, you can use incandescent lamp in place of an LED but it will run the battery down quicker and appear dimmer. Also, the special lighting effects will not appear as nice as they do when using an LED.

All lights connect between the V+ wire and the ALT light driver output. Do not connect to your factory supplied locomotive lights - they will burn out.

The light driver outputs are rated at a maximum of 1 Amp. They are not protected against shorts.

Multiple lights may be powered from a light driver output by wiring the LEDs in parallel or in series. Make sure not to exceed the 1 Amp rating.

Limit Resistor Value

The LED must always be used with a series limit resistor. The value of the limit resistor depends on the battery voltage, the LED color and the desired brightness. To determine the required resistor value, use the equation below. A white LED voltage is about 3.2V. Once you have calculated the resistor value, it can be rounded up to the closest standard 5% resistor value. The table below shows common values versus battery voltage for white LEDs running on 20mA. At 18V and below, a 1/4 watt sized resistor is adequate. Above 18V use a half watt resistor.

$$R \text{ (in ohms)} = [\text{Battery Voltage}] - [\text{LED voltage VF}] \text{ divided by } [\text{desired current in Amps}]$$

LED Color	BAT+	LEDVF	Current	Value	Closest 5% R	Rating
White	14.8V	3.2	0.02	580	620	quarter watt
White	18V	3.2	0.02	740	750	quarter watt
White	20V	3.2	0.02	840	910	half watt
White	22V	3.2	0.02	940	1000	half watt

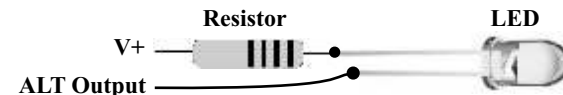

Physical Appearance
Long Lead is "A" or anode

LED Symbol

ALT Lighting Socket Pinout Information

This tables shows the pin number as well as any CVs that affect the attached LEDs appearance. Note that DLL and DLR are to be used as a pair for driving Ditchlight Left and Ditchlight Right. The next page describes how to setup the Ditchlight.

Pin	Name	Action CVs	Notes
1	V+	na	Battery Plus
2	DLL	53, 54, 55	CV Sets rate, mode, timeout
3	DLR	same as DLL	Same as DLL
4	AUX2	204	CV Sets Lighting effect
5	AUX3	205	CV Sets Lighting effect
6	not used	na	na

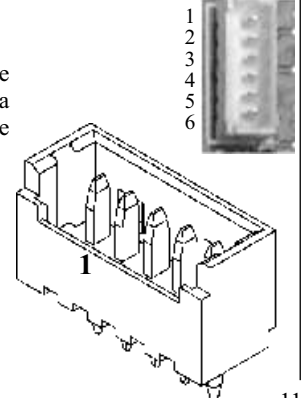

Customizing Ditch/Crossing Lights Operation

The Drop-in's ALT socket has two outputs designed for driving of ditch and/or crossing lights. In modern diesels, these lights alternately flash on and off when activated, usually for grade crossings. On the Drop-In, these are called ditch-light left, or DLL, and ditch-light-right, or DLR.

Ditchlights Have Directional Dependency

With the front headlight on, the ditchlights will also be on (unless the ditchlight mode is changed) and can be activated. But if the rear headlight is on and the forward headlight is off, the ditchlights will not turn on or flash if activated. If the headlights have been turned off with F0, the ditchlights will also be off and can't be activated.

Activating Ditchlight Flashing

Providing the locomotive's forward headlights have been turned on with F0, the factory setting for to activate the flashing ditchlights is throttle function 4, F4. After activation, the ditch lights begin to alternately flash on and off. They continue to flash until the timeout period has expired. The ditchlight mode setting determines if the ditchlights stay on after activation or turn off. The flash rate and the timeout period can be customized.

Ditchlight Mode Setting

The factory settings for the Ditchlight operation mode is for both of the ditch lights, DLL and DLR, to turn on whenever the front headlights are turned on. A value of zero sets the ditch lights to turn on with the headlights. This is the original factory value. A value of 1 keeps the ditch lights off until they are activated and begin flashing. Once the flashing has timed out, the ditch lights turn off.

Ditch Light Mode CV208
Range is 0-1 [0]

Ditchlight Flash Rate

The factory setting for the ditchlight flash rate is about a 3/4 second on followed by a 3/4 second off. This can be changed with the dedicated flash rate CV53. The value in CV53 sets the rate or frequency at which the ditch lights flash once activated. A value of one sets the highest rate or about 1/4 of a second. A value of 4 sets the rate to about 1 second. A value of 0 is rejected.

Ditch Light Flash Rate CV207
Range is 1-15 [3]

Ditchlight Timeout

Once the flashing has begun, the factory setting for the duration is about 15 seconds. This is called the timeout value and is stored in CV55. The value in CV55 sets the length of time, in seconds, for the duration of the ditchlight flashing. A value of 0 is rejected.

Any time when the ditch lights are flashing, pushing F4 resets the timer for another 15 seconds of flashing. Once the timer expires, the ditch lights return to both on [mode dependent]. Also, the flashing can be terminated early by turning off the headlights with F0.

Ditch Light Timeout CV209
Range is 1- 255 [15]

Ditch Lights Are Turned On With The Headlights - F0

Additional CVs And Information Not Detailed Elsewhere

Decoder Address CV1
Range is 1-9999 [3]

When SERVICE PROGRAM is used to set the decoder address, the throttle actually sends a group of commands to set CV1, CV17, CV18 and CV29. That is why you hear as many as 3 chirps when CV1 is set to the desired address from 1 to 9999. Do not use address 0, it is not supported.

Loss of Signal Timer (LOS) CV11
Range is 0-255 seconds [0]

Fail-safe Operation - If your locomotive goes out of range of the throttle or the throttle is no longer transmitting, you can set the locomotive to either continue running or stop after a preset amount of time. The timer range is 1 seconds to 255 seconds. A value of zero means the locomotive runs forever, or until the battery runs down.

If CV11 = 0 this selects continuous operation. In other words, the locomotive continues to operate at the last received speed command forever. The assumption is that it will eventually come back into range of the locomotive. Another reason to use continuous running is because you want to control several trains with a single throttle. Changing the throttle's address to control a new address means the original address is no longer being used. This is the same as turning the throttle off or going out of range. With the decoder set to operate continuously, the locomotive will continue to run at the last received speed command. To regain control, first set the speed knob and direction close to the locomotive's current speed and then select the new address.

If CV11 value is not equal to zero, then the locomotive will come to a smooth halt after the timer value counts down to zero.

Loco Address High Byte CV17
Range is 0-255 [0]

Loco Address Low Byte CV18
Range is 0-255 [0]

CV17 and CV18 are automatically set based on the setting of CV1 to the desired locomotive address. We do not recommend that manually changing these CVs. Use CV1 when programming the decoder address so they are set automatically.

Decoder Setup CV29
Range is 0-255 [2]

CV29 is a multipurpose CV whose value sets several options at once. The NW2 Drop-In sets this CV automatically for you so there should be no need to change it. However, if you accidentally change it and the locomotive no longer runs, you can either reset it back to a value of 2 or use a factory reset to erase all changes and restore CV29 to its default value of 2.

Decoder Frequency Number CV200
Range is 0-16 [0]

CV200 holds the assigned frequency number for the NW2 Drop-In decoder. If a number larger than 16 is attempted, the decoder rejects it and automatically sets itself to frequency 0. If you have forgotten the frequency, see page 16 for the procedure to temporarily force the NW2 Drop-In to a known frequency.

Drop-In Cruise Control

The Drop-In decoder comes equipped with a new and advanced cruise control design for maintaining the speed of a locomotive. Just like the cruise control in an automobile, once activated the locomotive will maintain the same average speed independent of the load or the terrain of your layout. It will cruise up hill and down hill as well as snake through tight curves and turnouts while maintaining the same average speed automatically without user's intervention.

New on the Drop-In are two extra CVs, CV64 and CV65. These allow you to finely tune your cruise control to your specific locomotive.

Cruise Mode Setting

The Drop-In is shipped from factory with the cruise control disabled until you activate it with a function key (F5 is the factory default activation key). When activated the decoder will chirp one time. Pressing the function key again will not deactivate the cruise control. Deactivation depends on the selected cruise mode. The cruise mode is explained below. Once deactivated, the cruise control can only be reactivated again by pressing the function key. The decoder chirps each time it goes into or out of cruise control.

Cruise Mode Select CV63
Range is 0- 1 [0]

There are two different types or modes of cruise control.

Cruise mode 0 (factory default setting), when activated, will hold the locomotive speed constant and independent of the load, grade or track curves. If the throttle speed is change, up or down, or the direction is reversed, cruise control is deactivated. Mode 0 is easy to use. Once the train reaches the desired speed, push F5 (or what ever key you have assigned to activate cruise control) to enable cruise.

Cruise mode-1 is unique in that once cruise is active, you may change the cruising speed without deactivating cruise control. This allows fine tuning of the cruise speed, either higher or lower. As with the other mode, push F5 to enable cruise mode. In this mode, you can make changes to the initial speed using the throttle speed knob. You may increase or decrease the speed. Taking the throttle to 0 or reversing the direction will turn off cruise mode. To turn it back on, just push F5 again. The decoder chirps each time it goes into or out of cruise control.

Cruise Tracking Rate CV64
Range is 1- 16 [4]

CV64 selects the tracking rate with which the cruise control checks the locomotive speed. The value for CV64 has a range of 1 to 16 and the factory default value is set at 4. The lower the value of CV64 is, the more often the cruise control checks and corrects the locomotive cruise speed. We have found that the optimal setting to be about 4 although you can try different values since your locomotive and layout conditions might be somewhat different than ours.

Cruise Correction Step Size CV65
Range is 1- 3 [2]

CV65 sets the amount of correction when a motor speed adjustment has to be made. The default value of 2 works well for most locomotives. A value of 1 means the speed corrections are finer but it will take longer to adapt to a large change in speed. A value of 3 creates larger corrections and tracks speed changes much faster but with 50% less precision than a value of 2.

CAUTION: Do not use a value of 0 for either CV 64 or 65. If you accidentally use 0, the NW2 Drop-In will automatically reject it and instead use the factory default values.

Be Careful Using Cruise Control With Multi-unit Consists

If locomotives are in a multiunit consist, cruise-control may fight each other. However, if all locos are relatively closely matched, cruise mode 1 may be the best mode. Experiment to determine which cruise mode works best for your fleet.

Assigning Special Effects To Other ALT Light Drivers

There are a variety of special effects that can be applied to the CAB, AUX1 and AUX2 lights as well as the SMOKE generator. Here's the table of CVs related to the Drop-In lighting outputs. The headlight effects are described elsewhere and the ditchlights have their own section. The * means not all AUX lights are available on all Drop-Ins. See your locomotives User Manual for what's on yours.

CV201	3	1-15	Light Effect Period (x512ms)
CV202	4	0-15	CAB Special Effect [E1]
CV203	4	0-15	AUX1 Special Effect [E2]
CV204	4	0-15	AUX2 Special Effect [E3]
CV205	4	0-15	E4 Special Effect*
CV206	0	0-255	E4 Auto-off Timer*

To use an effect, first select the CV number for the specific LITE to be changed. Next find the desired effect in the effects table and note its CV value. Finally, load this value into the CV number. The original factory CV value is 4 for each of the LITE effects. This means they turn on at full brightness when activated.

Effect Timing Rate CV201
Range is 1-15 [3]

CAB LITE Effect CV202
Range is 0-15 [4]

AUX1 Effect CV203
Range is 0-15 [4]

AUX2 Effect CV204
Range is 0-15 [4]

AUX3 Effect CV205
Range is 0-15 [4]

Lighting effects that include a repeating pattern have a variable rate or speed at which the pattern is repeated. The rate or speed at which the pattern is repeated is based on the value set into CV201. Bigger numbers represent slower repeat times. The period CV does not apply when the selected effect is either full bright, dim or random flickering.

A value of 0 shouldn't be used. However, although if you accidentally enter 0, the decoder will automatically change it to a value of 1.

This table summarizes the lighting effects and the CV value to activate the lighting effect. Also shown is whether the timing rate applies to these effects. All of these effects are optimized for LED lighting.

Special Lighting Effects	CV Value	CV201 Applies
Off 0% - <i>should not be used</i>	0	No
Dim 6%	1	No
Dim 25%	2	No
Dim 50%	3	No
On 100%	4	No
Strato Light	5	Yes
Oscillating Light	6	Yes
FRED	7	Yes
Rotary Dome light 1	8	Yes
Gyra Light	9	Yes
Mars Light	10	Yes
Rotary Dome Light 2	11	Yes
Strobe Single Pulse	12	Yes
Strobe Double Pulse	13	Yes
Reserved	14	No
Random flicker	15	No

Additional LED Hookup Options

Series Hookup of LEDs

LEDs can be connected in series, one connected to the other. A common application is when a locomotive has a dual-beam headlight.

Since the LEDs are in series, they each get the same current which is 0.02A. However, since two LEDs are in series, calculating the resistor requires that 2 times the LED-VF value be used.

The table below shows the new resistor value for two LEDs in series.



LED Color	BAT+	LED VF	Current	Value	Closest R	Rating
White	14.8V	3.2 x 2=6.4V	0.02	420	430	quarter watt
White	18V	6.4	0.02	580	620	quarter watt
White	20V	6.4	0.02	680	750	half watt
White	22V	6.4	0.02	780	810	half watt
White	24V	6.4	0.02	880	910	half watt

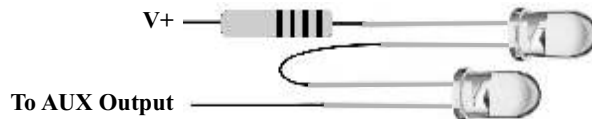

Parallel Hookup of LEDs

LEDs can be connected in parallel. The only difference is that each LED must have its own limit resistor. Otherwise, they will not share the current equally resulting in different brightness for each one.

For parallel LEDs, the series resistor will be the same value as if there was only a single LED.

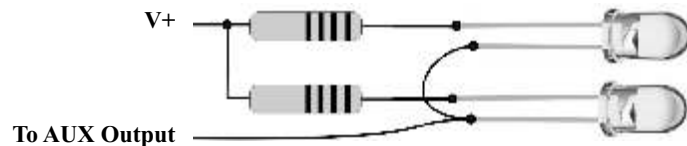

Locomotive Speed Matching Tips

Using CV2, CV6 and CV5, you can match the speeds of two or more different locomotives. One important consideration is to determine which locomotive in a consist is the slowest. It is to this slow locomotive that you will match the other members of the consist. Always match a locomotive to the slowest member of the consist since we cannot make a slow locomotive run faster than its top speed. The following examples illustrate some of the possible ways to match up locomotives.

You may find that matching locomotives at the top and mid point speeds is close enough. By all means you may stop if you are happy with the performance after steps 1 and 2. The procedures below allow you to precisely match locomotive speeds at all speed steps, not just two. The penalty is a bit more time but you will be impressed with the results.

Use OPS mode programming to make changes to the CVs.

Step 1: Match locomotives at step 14

Using the slower locomotive as reference, match the faster locomotive to the speed of the slower one at speed step 14 using CV6. Since we are modifying CV6 of the faster locomotive, we should reduce the value of CV6 until it matches the speed of the slower locomotive. At this point, both locomotives should be running at the same speed at speed step 14.

Step 2: Match locomotives at top speed

Using the slower locomotive as reference, match the faster locomotive to the speed of the slower one at speed step 28 using CV5. Since we are modifying CV5 of the faster locomotive, we should reduce the value of CV5 until it matches the speed of the slower locomotive. At this point, both locomotives should be running at the same speed at speed step 28.

Step #3: Fine tuning the top speed setting only (2 methods)

Using the slower locomotive as reference, compare the speed of both locomotives at speed step 21 (middle of the high speed setting). If both locomotives are running at more or less the same speed then no fine tuning is necessary. If not then fine tuning the high speed setting may be done next. There are two ways, using CV5 or CV6 only.

Using CV5 only is the first method and results in minor speed differences at step 28.

Reference Locomotive Is Either Slower or Faster At Step 21: Decrease the value of CV5 of the other locomotive to match the speed of the reference. Conversely, if the reference locomotive is running faster at speed step 21, then increase CV5 of the other locomotive to match the speed of the reference. Using this method can result in minor speed difference in top speed.

Using CV6 is an alternative method and results in minor speed differences at step 14.

Reference locomotive is running slower or faster at speed step 21, then lower CV6 of the other locomotive to match the speed of the reference. Conversely, if the reference locomotive is running faster at speed step 21, then increase CV6 of the other locomotive to match the speed of the reference.

Step #4: Fine tuning the low speed setting only (2 methods).

Using the slower locomotive as reference, compare the speed of both locomotives at speed step 7 (middle of the low speed setting). If both locomotives are running at more or less the same speed then no fine tuning is necessary. If not then fine tuning the low speed setting may be done next. There are two ways, using CV6 or CV2 only.

Using CV6 is the first method and results in minor speed differences at step 14.

Reference locomotive is running slower at speed step 7: lower CV6 of the other locomotive to match the speed of the reference. Conversely, if the reference locomotive is running faster at speed step 7, then increase CV6 of the other locomotive to match the speed of the reference.

Using CV2 is the alternative method and results in minor speed difference at step 1.

Reference locomotive is running slower at speed step 7: lower CV2 of the other locomotive to match the speed of the reference. Conversely, if the reference locomotive is running faster at speed step 21, then increase CV2 of the other locomotive to match the speed of the reference.

Improve Slow Speed Running With Bumping

Many users assume that CV2 is used to control how the locomotive starts up at slow speeds. However, you should not use CV2 for that purpose. Instead take advantage of the advanced NW2 Drop-In feature of motor bumping.

We have completely redesigned the bumping algorithm to provide for precision slow speed control. The new algorithm uses a sophisticated algorithm that you can customize using CV56 and CV57. The new bumping feature perfectly compliments the ultra high resolution speed curve created with CV2, CV5 and CV6.

With motor bumping, you can achieve silky smooth performance at very low speeds. There are two CVs for this feature, the motor bump value, CV56 and the motor bump duration, CV57. Your NW2 Drop-In will automatically transition from the slow-speed bump to the high resolution speed curve operation as the locomotive gains speed.

Motor Bump Value **CV56**
Range is 0-255 [0]

This value sets the amount of momentary motor voltage increase, called a bump, applied at each speed step to the help motor overcome friction. It helps get the motor rotating at a lower voltage and/or a lower speed step. Once the locomotive is moving, the bump automatically goes away. A value of 0 turns off the motor bump. A value of 128 will literally apply half of full speed to the motor.

Motor Bump Duration **CV57**
Range is 0-127 [0]

This value selects the duration of time that the bump value is applied when the bump is active. A value of 0 disables the bump completely, no matter what is set in CV56.

Experimenting With Motor Bumping

To use the motor bump feature, the following procedure is recommended. Be sure to use a throttle that shows the speed step being sent such as the T5000.

Step 1: Set the throttle to speed step 1 and observe the locomotive's wheels. They may or may not be turning.

Step 2: Set CV56 to a value of 15 and CV57 to a value of 50. Observe the locomotive wheels and see if they are now turning. Stop and then return the throttle to step 1. Look for consistent forward motion and make sure that the bump is sufficient for smooth operation over the entire length of the track at speed step 1.

Step 3: If the wheels are not yet turning, increase either CV56 or CV57 or both by a value of 5 and check again. You should make changes to the CV values in increments of 5. Smaller increments may not cause any noticeable changes.

There is a tradeoff between the bump value and the bump duration. If a small bump value is applied, then a longer bump duration will be needed. Or, if a large bump value is used, it can be applied for a shorter duration.

Careful choices of CV56 and CV57 will give not only fine control at slow speeds but allow the full range of precision speed control over the entire speed curve. Think of the motor bump as an added feature that provides an extra boost of energy to get the locomotive moving at low speeds.

New Motors Should Be Broken In Before Using

A new motor usually doesn't have motor brushes that conform well to the circular shaft of the commutator. The brushes tend to draw more than normal current, and exhibit arcing. As a result, the motor causes lots of radio noise and can even trip the NW2 Drop-In over-current protection circuit. To prevent this from occurring, just run the motor for an hour or so at full speed and in each direction. This will seat the motor brushes and greatly reduce radio noise generation.

Motor Control And Speed Curve Fine Tuning

There are 3 CVs that determine how the locomotive motor responds to a throttle speed command. Following the NMRA-DCC standard, these are: CV2 (Vstart or motor-starting-voltage MSV) CV6 (Vmid), and CV5 (Vmax). The full scale motor voltage value ranges from 0 to 255 so these 3 variables also have a value range of 0 to 255. You may set these values to suit your desired locomotive performance as well as to help with speed matching of different locomotives.

Note: regardless of the throttle's speed step setting, the NW2 Drop-In will automatically adjust for the 14 speed step or the 28 speed step settings.

Motor Starting Voltage Value (MSV) **CV2**
Range is 0-255 [9]

CV2 sets the MSV of the motor voltage that corresponds to speed step 1 (in a 28 speed step setting). This is the first speed step from off, or zero voltage. You can decide if you wish the motor to be moving at a good rate of speed or just barely moving by changing the MSV. A small MSV value means only a small extra increase in motor voltage. A larger MSV value means the motor receives a higher motor voltage. Also consider modifying the motor bumping feature described on page 24 since the two settings are somewhat interactive.

Mid-point Motor Voltage Value (Vmid) **CV6**
Range is 0-255 [128]

The mid-point voltage, or half speed, corresponds to speed step 14 (in a 28 speed step setting). CV6 is used to set this voltage with 128 being the factory default value. If a lower half speed is needed, for example in speed matching application, set CV6 to a smaller value. Speed curve #3 lowers the half speed to 55. So at speed step 14, the locomotive is running at 25% of the maximum motor voltage. Conversely, if the locomotive is running too slow at speed step 14, CV6 can be raised to increase the half speed.

continued on next page

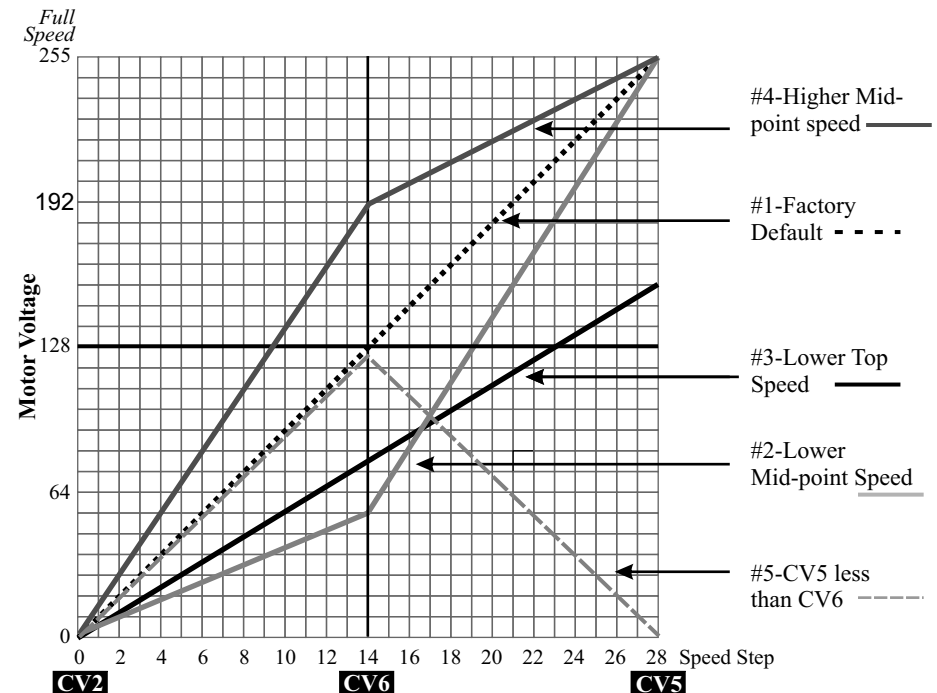

Locomotive Motion Control and Fine Tuning *continued*

Maximum Motor Voltage Value (Vmax) CV5
Range is 0-255 [255]

The top speed voltage (full speed) corresponds to speed step 28 (in a 28 speed step setting). CV5 is used to set this voltage and 255 is the factory default. If a lower top speed is needed, for example in speed matching application, set CV5 to a smaller value. Speed curve #2 lowers the top speed to 155. So at speed step 28, the locomotive is running at 60% of the maximum motor voltage. It should be noted that every speed step from 1 to 28 will be slower accordingly.

Setting CV5 to a value less than CV6 is OK but the resultant speed curve will be an upside down V. Curve #5 on the previous page shows the extreme case with CV5 equal 0 and CV6 equal to 128. The motor will reach top speed at step 14 and then gradually slow down to a stop at step 28.

Customizing The Speed Curve To Your Requirements

Customizing a speed curve is easily done by modifying one or more of the three configuration variables. It helps to visualize the speed curve as having two separate halves as shown in the graph with the split at the 50% throttle speed position. The left half is controlled by CV2 and CV6 and responds to the first 14 speed steps (in the 28 speed step setting). The right half is controlled by CV6 and CV5 and responds to speed steps 15 to 28 (in the 28 speed step setting).

I want finer slow speed control: With CV2 and CV5 unchanged, the step size of speed steps 0 to 14 in the left half of the speed curve can be reduced to give finer control by simply reducing the value of CV6 from the default 128 to a smaller value. For example, by reducing CV6 to 100, each of the 14 steps will be reduced by a value of 2. As a result of reducing CV6 to 100, the step size for speed steps from 15 to 28 in the right half of the speed curve increase by a value of 2. The result is curve #3. Thus, you gain finer speed control at the low end of the throttle range at the expense of bigger steps at the high end. For yard operations, you will find this setting to offer precision slow speed control right when you needed it.

I want finer high speed control: With CV2 and CV5 unchanged, the step size of speed steps 15 to 28 in the right half of the speed curve can be reduced to give finer control by simply increasing the value of CV6 from the default 128 to a larger value. For example, by increasing CV6 to 156, each of the 14 steps will be increased by a value of 2. The result is curve #4. It is important to remember that as a result of increasing CV6 to 156, the step size for steps 0 to 14 in the left half of the speed curve would be increased by a value of 2.

I want both finer speed steps for slow and high speed control: With CV2 unchanged, the step size of speed steps 0 to 28 can be reduced to give finer control by simultaneously reducing the values of CV6 and CV5 to a smaller value. For example, by reducing CV6 from a default of 128 to 100, and CV5 from a default of 255 to 227, the step size for the entire speed curve is now reduced by a value of 2 to give finer control. The result is curve #2. By reducing CV5 to a smaller value, the top speed at the high end is lower which will result in less torque at high throttle settings.

CV2 has remained unchanged in the above examples. The next set of examples, shows what you can do by modifying CV2. These are not graphed but are discussed to show that you can create an unlimited variety of speed curves using just 3 different CVs.

I want a higher MSV with finer slow and high speed control: With CV5 unchanged, the step size of speed steps 0 to 28 can be reduced to give finer control by simultaneously increasing the values of CV2 and CV6 to a larger value. For example, by increasing CV2 from a default of 9 to 37, and CV6 from a default of 128 to 156, the step size for the entire speed curve is now reduced by a value of 2 to give finer control. By increasing CV2 to a larger value, the MSV is now higher for the low end starting speed of speed step 1.

I want higher MSV and reduced top speed with finer slow and high speed control: With CV6 unchanged, the step size of speed steps 0 to 28 can be reduced to give finer control by simultaneously increasing CV2 to a larger value and reducing CV5 to a smaller value. For example, by increasing CV2 from a default of 9 to 37, and reducing CV5 from a default of 255 to 227, the step size for the entire speed curve is now reduced by a value of 2 to give finer control. This also results in a reduced top speed at speed step 28 and an increased starting speed at speed step 1.

Motor Acceleration and Deceleration Control

Locomotive inertia and momentum are simulated using CV3 and CV4. Inertia is the rate at which a locomotive accelerates when changing from a slow speed to a higher speed. Contrast that with momentum which is the rate at which a locomotive decelerates from a high speed to a lower speed.

CV3 deals with the rate of acceleration when the speed is increased. In other words how quickly does the operator intend for the locomotive to accelerate. The smaller the value of CV3 the quicker a locomotive will accelerate. Similarly, CV4 deals with the rate of deceleration and the smaller the value of CV4 the quicker the locomotive will decelerate.

Motor Acceleration Rate. CV3
Range is 1-255 [2]

This CV sets the rate of change of locomotive speed when the throttle speed is increased. This is called the acceleration rate. Small values mean the rate of change is fast. A higher value leads to a slower rate of change.

In most cases, users prefer a *slower* rate of change for the acceleration rate. Common values are 3, 4 and 5. Large values result in extremely long delays for speed changes to take effect which are generally uncomfortable for users. The acceleration rate applies equally in the forward and reverse directions.

Motor Deceleration Rate CV4
Range is 1-255 [2]

This CV sets the rate of change of speed upon when the throttle speed is decreased. This is called the deceleration rate. Small values mean the rate of change is faster. A higher value leads to a slower rate of change.

In most cases, users prefer a *faster* deceleration rate compared to the acceleration rate. The factory default of 2 is seldom changed. High values will result in extremely long delays for locomotives to slow down. If you imagine your favorite locomotive speeding towards another train, you will want to be able to quickly stop the train. This is why the factory setting of 2 is seldom changed. Users want to slowly start the train, but quickly stop it. The value applies equally in the forward and reverse directions.

GearSaver Protection

If for some reason, you set CV3 or CV4 to 0 in an attempt to achieve instantaneous stop or quick acceleration, NW2 Drop-In will automatically set CV3 or CV4 to 1 instead, in order to protect the locomotive gears from being stripped. So the effective range for CV3 and CV4 is from a value of 1 to 255.

Also, if you reverse the locomotive direction without first stopping it, GearSaver protects you again. In this situation, NW2 Drop-In will ramp the speed down to zero before reversing the direction and

Beware Of Large Values

Large values for acceleration or deceleration rates will result in very slow response to throttle changes. Extreme values will result in the locomotive never starting, or, never stopping - neither of which is very comfortable to the operator.